

# ProVecta 3D Prime and ProVecta 3D Prime Ceph

EN-  
US



Installation instructions

CE 0297

RxOnly

2210201032L41



**AIR**  
**TECHNIQUES** equipped for life®

A7867

2108V005

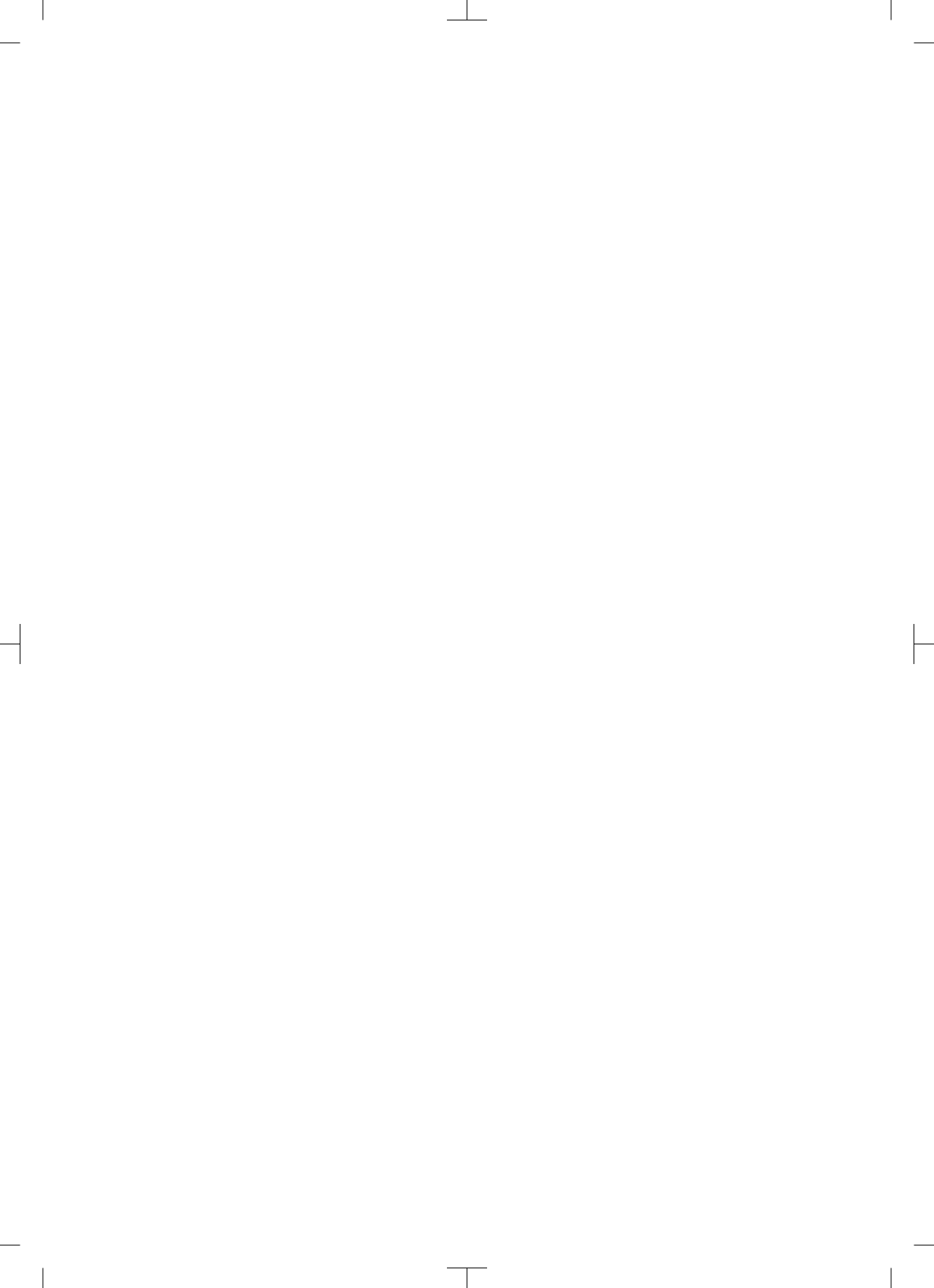

# Contents



## Important information

<b>1 About this document</b> . . . . .	2
1.1 Warnings and symbols . . . . .	2
1.2 Copyright information . . . . .	3
<b>2 Safety</b> . . . . .	4
2.1 Intended use and indication . . . . .	4
2.2 Contraindications . . . . .	4
2.3 Improper use . . . . .	4
2.4 General safety information . . . . .	4
2.5 Radiation protection . . . . .	4
2.6 Specialist personnel . . . . .	5
2.7 Protection from electric shock . . . . .	5
2.8 Essential performance characteristics . . . . .	6
2.9 Notification requirement of serious incidents . . . . .	6
2.10 Only use genuine parts . . . . .	6
2.11 Transport . . . . .	6
2.12 Disposal . . . . .	6
2.13 Protection from cybersecurity threats . . . . .	6



## Product description

<b>3 Overview</b> . . . . .	7
3.1 ProVecta 3D Prime . . . . .	7
3.2 ProVecta 3D Prime Ceph . . . . .	8
3.3 Scope of delivery . . . . .	9
3.4 Optional items . . . . .	10
3.5 Consumables . . . . .	10
<b>4 Technical data</b> . . . . .	11
4.1 X-ray tube performance data . . . . .	12
4.2 Dimensions . . . . .	17
4.3 Model identification plate . . . . .	19
4.4 Conformity assessment . . . . .	19
<b>5 Function</b> . . . . .	20
5.1 3D and panoramic X-ray unit . . . . .	20
5.2 Cephalometric X-ray unit . . . . .	20
5.3 Status LED . . . . .	20

5.4 Positioning aids . . . . .	21
5.5 Positioning aids for cephalometric projections . . . . .	21
5.6 Exposure button . . . . .	22
5.7 Memory card slot . . . . .	22
5.8 Sensor window . . . . .	22



## Installation

<b>6 Requirements</b> . . . . .	24
6.1 Installation/setup room . . . . .	24
6.2 System requirements for the reconstruction computer . . . . .	25
<b>7 Installation</b> . . . . .	26
7.1 Checks before unpacking . . . . .	26
7.2 Unpacking the unit . . . . .	26
7.3 Setting up the unit . . . . .	28
7.4 Preparation of the reconstruction computer . . . . .	46
7.5 Connecting the unit . . . . .	46
<b>8 Commissioning and first start-up</b> . . . . .	51
8.1 Switch the device on . . . . .	51
8.2 Electrical safety checks . . . . .	52
8.3 Limiting the height adjustment . . . . .	52
8.4 Checking the installation . . . . .	53
8.5 Calibrating the unit . . . . .	53
8.6 Carrying out a functional test . . . . .	54



## Troubleshooting

<b>9 Tips for operators and service technicians</b> . . . . .	56
---	----

## ! Important information

### 1 About this document

These installation and operating instructions are an integral part of the unit.

 Air Techniques shall not be held liable and offers no guarantees of the safe and smooth operation of this unit if you fail to comply with notes and instructions contained in these Installation and Operating Instructions.

The German version of the operating instructions is the original manual. All other languages are translations of the original manual.

These operating instructions are valid for the Pro-Vecta 3D Prime, order number: A7761 and Pro-Vecta 3D Prime Ceph, order number: A7861.

#### 1.1 Warnings and symbols

##### Warnings

The warning notes in this document highlight possible injury to persons or damage to machinery.

They are marked with the following warning symbols:

 General warning symbol

The warnings are structured as follows:



##### SIGNAL WORD

##### Description of type and source of danger

Here you will find the possible consequences of ignoring the warning

- › Follow these measures to avoid the danger.

The signal word differentiates between different levels of danger:

- **DANGER**  
Direct danger of severe injury or death
- **WARNING**  
Possible danger of severe injury or death
- **CAUTION**  
Risk of minor injuries
- **NOTICE**  
Risk of extensive material/property damage

##### Miscellaneous symbols

These symbols are used in the document and on or in the unit:

 Note, e.g. specific instructions regarding the efficient use of the unit.

 Part number

 Serial number

 Medical device

 CE labeling with the number of the notified body

 Manufacturer

 Caution: By virtue of Federal Law, the software may only be sold to dentists or bought on behalf of a dentist.

 Dispose of correctly in accordance with EU Directive 2012/19/EU (WEEE).

 Type BF applied part

 Do not reuse

 Not sterile

 Sterilize with steam at 134 °C

 Protective ground connection

 Equipotential bonding

 Fragile, handle with care

 Lower and upper atmospheric pressure limits

 Lower and upper temperature limits



Lower and upper humidity limits



Stacking limits



Recycling



Keep dry



This way up / store and transport in an upright position



Keep away from sunlight during storage



Refer to Operating Instructions.



Wear hand protection.



Wear eye protection.



Use a mask.



Wear protective clothing.



Disconnect all power from the unit.



Notice



Emergency stop switch



Laser class 1



Warning – X-rays



Warning – risk of dangerous electric voltages



Warning – X-rays

## 1.2 Copyright information

All electronic drawings, processes, names, software, and appliances mentioned here are protected under copyright.

Printing or copying these Installation and Operating Instructions, including excerpts thereof, may only be carried out with the written approval of Air Techniques.

## 2 Safety

The unit has been developed and designed appropriately such that hazards are largely excluded if the unit is used in accordance with its Normal Use.

Despite this, the following residual risks can remain:

- Personal injury due to incorrect use/misuse
- Personal injury due to mechanical effects
- Personal injury due to electric shock
- Personal injury due to radiation
- Personal injury due to fire
- Personal injury due to thermal effects to skin
- Personal injury due to lack of hygiene, e.g. infection

### 2.1 Intended use and indication

#### ProVecta 3D Prime

ProVecta 3D Prime is computed tomography x-ray unit intended to generate 3D and panoramic X-ray images in dental radiography for adult and pediatric patients. It provides diagnostic details of the maxillofacial areas for a dental treatment.

The device is operated and used by physicians, dentists, and x-ray technicians.

Not intended for mammography use.

#### ProVecta 3D Prime Ceph

ProVecta 3D Prime Ceph is a computed tomography x-ray unit intended to generate 3D, panoramic and cephalometric X-ray images in dental radiography for adult and pediatric patients. It provides diagnostic details of the maxillofacial areas for a dental treatment.

The device is operated and used by physicians, dentists, and x-ray technicians.

Not intended for mammography use.

#### Other positioning aids

The accessory is intended to be used for positioning the patient for the dental radiographic examination.

### 2.2 Contraindications

The radiobiological effects of X-ray beams in tissue result in the following contraindications:

- Pregnancy
- Pre-existing illnesses preventing the recording of a CBCT image
- Absence of a justified indication

Exceptions can be formulated at the discretion of the physician.

### 2.3 Improper use

Any use of this appliance/these appliances above and beyond that described in the Installation and Operating Instructions is deemed to be incorrect usage. The manufacturer cannot be held liable for any damage resulting from incorrect usage. The operator will be held liable and bears all risks.

### 2.4 General safety information

- › Comply with the guidelines, laws, rules and regulations applicable at the site of operation when you use this unit.
- › Prior to each use, check the function and proper condition of the device.
- › Do not convert or modify the unit.
- › Comply with the Installation and Operating Instructions.
- › Make the Installation and Operating Instructions always available to the operator in the vicinity of the device.

The sale or prescription of this device by a medical practitioner is subject to the restrictions of the applicable Federal Acts. The device may be used only under permanent supervision by a dentist or licensed medical practitioner.

**Rx<sub>only</sub>** Caution: By virtue of Federal Law, the software may only be sold to dentists or bought on behalf of a dentist.

### 2.5 Radiation protection

- › Comply with all applicable X-ray protection regulations and X-ray protection measures.
- › Use the prescribed X-ray protection equipment.
- › In order to reduce the level of X-ray exposure, we recommend the use of bismuth, lead shielding or protective aprons, especially for children and teenagers.
- › The persons operating the equipment must keep away from the X-ray unit while the exposure is being taken. The minimum distance required by the law must be maintained.
- › Children and pregnant women must consult a doctor before recording an X-ray image.

- › No person other than the patient is permitted to be present in the radiation room without X-ray protection measures. In exceptional circumstances another person may be present to provide assistance, but this must not be a member of the surgery staff. When the exposure is being taken, make sure that you maintain visual contact with the patient and the unit and keep talking to the patient.
- › The radiation room must be lockable to prevent entry by unauthorized persons.
- › If a fault occurs, abort the exposure immediately by releasing the trigger button.
- › Note that cable lengths and cable extensions have effects on electromagnetic compatibility.
- › No maintenance measures are required to maintain the basic EMC safety.
- › The emissions characteristics of this device render it suitable for use in industrial environments and hospitals (CISPR 11, Class A). When used in a residential environment (which normally requires Class B in accordance with CISPR 11), this device may not provide adequate protection from radio communication services. The operator may need to take corrective measures such as relocating or reorienting the device.

## 2.6 Specialist personnel

### Operation

Persons operating the unit must ensure safe and correct handling based on their training and knowledge.

- › Instruct or have every user instructed in handling the unit.

### Installation and repairs

- › All installation, resetting, alteration, expansion, and repair work must be carried out either by Air Techniques personnel or by a suitably qualified person approved by Air Techniques.

## 2.7 Protection from electric shock

- › Comply with all relevant electrical safety regulations when you work with this unit.
- › Never touch the patient and unshielded plug connections of the device at the same time.
- › Replace any damaged cables or plugs immediately.

### Comply with the EMC rules concerning medical devices

The unit meets the requirements according to IEC 60601-1-2:2014.

- › The unit is intended for use in professional healthcare facilities (in accordance with IEC 60601-1-2). If the unit is operated in any other environment, potential effects on the electromagnetic compatibility must be taken into account.
- › Do not use the device near HF surgical devices and MRI equipment.
- › Keep a minimum distance of 30 cm between the device and other electronic devices.



### NOTICE

#### Negative effects on the EMC due to non-authorized accessories

- › Use only Air Techniques accessories or accessories approved by Air Techniques.
- › Using any other accessories may result in increased electromagnetic interference emissions or the unit having reduced electromagnetic immunity, leading to an erroneous operation mode.



### NOTICE

#### Erroneous operation mode due to use immediately adjacent to other devices or with other stacked devices

- › Do not stack the unit together with other devices.
- › If this is unavoidable, the unit and other devices should be monitored in order to ensure that they are working correctly.



### NOTICE

#### Reduced performance features due to insufficient distance between unit and mobile HF communication devices

- › Keep at least 30 cm distance between the unit (including parts and cables of the unit) and mobile HF communication devices (wireless units) (including their accessories such as antenna cables and external antennas).

## 2.8 Essential performance characteristics

The unit does not have any essential performance characteristics as set out in IEC 60601-1 section 4.3.

## 2.9 Notification requirement of serious incidents

The operator/patient has to report any serious incident related the product to the manufacturer and the competent authority of the Member State, in which the operator and/or patient is established/resident.

## 2.10 Only use genuine parts

- › Only use accessories and optional items specified or approved by Air Techniques.
- › Only use original working parts and spare parts.



Air Techniques accepts no liability for damage resulting from the use of non-approved accessories, optional items or any parts other than original spare and wear parts.

The use of non-approved accessories, optional items or non-genuine wear parts / replacement parts (e. g. mains cable) can adversely affect the electrical safety and EMC.

The following accessories may affect EMC:

- Mains cable (3.6 m; order no.: A7782)
- Exposure switch (order no.: A7801)

## 2.11 Transport

Only the original packaging ensures optimum protection for the unit during transport. If necessary, the original packaging for this unit can be ordered from Air Techniques.



Air Techniques cannot be held responsible for any damage resulting from transport in unsuitable packaging, even during the warranty period.

- › Only transport the unit in its original packaging.
- › Keep all packaging away from children.
- › Reattach the transport locking devices.
- › Do not expose the unit to any strong vibrations or shocks.
- › Do not bump or pull the unit.

## 2.12 Disposal

### Device

The units and electronic circuits may be disposed of only in proper facilities for recycling and recovery. Make sure to dispose of these objects in compliance with the applicable laws and regulations of the federal, national, state and municipal authorities.

### X-ray emitter

The X-ray emitter contains a tube that is potentially capable of imploding, lead cladding and mineral oil.

## 2.13 Protection from cybersecurity threats

The unit is to be connected to a computer that can be connected to the Internet. Therefore, the system needs to be protected from threats from the Internet.

- › Use antivirus software and update it regularly. Look for evidence of possible virus infection and, if applicable, check with the antivirus software and remove the virus.
- › Perform regular data backups.
- › Provide access to units only to trustworthy users, e.g. by means of user name and password.
- › Make sure that only trustworthy contents are downloaded. Install manufacturer-authenticated software and firmware updates only.



 Product description

### 3 Overview

#### 3.1 ProVecta 3D Prime

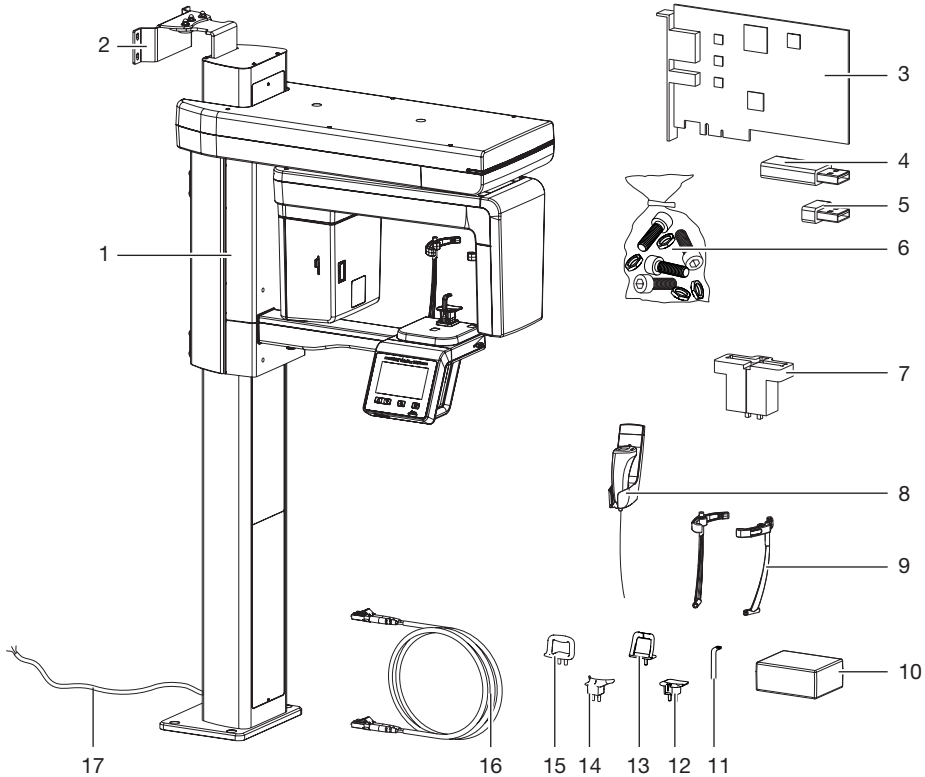

- |   |   |    |   |
|---|---|----|---|
| 1 | 3D and panoramic X-ray unit                           | 10 | Hygienic protective covers for bite block |
| 2 | Wall bracket  | 11 | Bite block                                |
| 3 | Frame grabber card                                    | 12 | Holder for bite block                     |
| 4 | USB dongle  | 13 | Chin holder for maxillary joint image     |
| 5 | USB stick containing device-specific calibration data | 14 | Chin support for edentulous jaws          |
| 6 | Small parts   | 15 | Chin holder for sinus image               |
| 7 | Pano test phantom holder                              | 16 | Fiber optic cable                         |
| 8 | Exposure switch (with holder)                         | 17 | Mains cable for permanent connection      |
| 9 | Head supports with cushion                            |    |   |

### 3.2 ProVecta 3D Prime Ceph

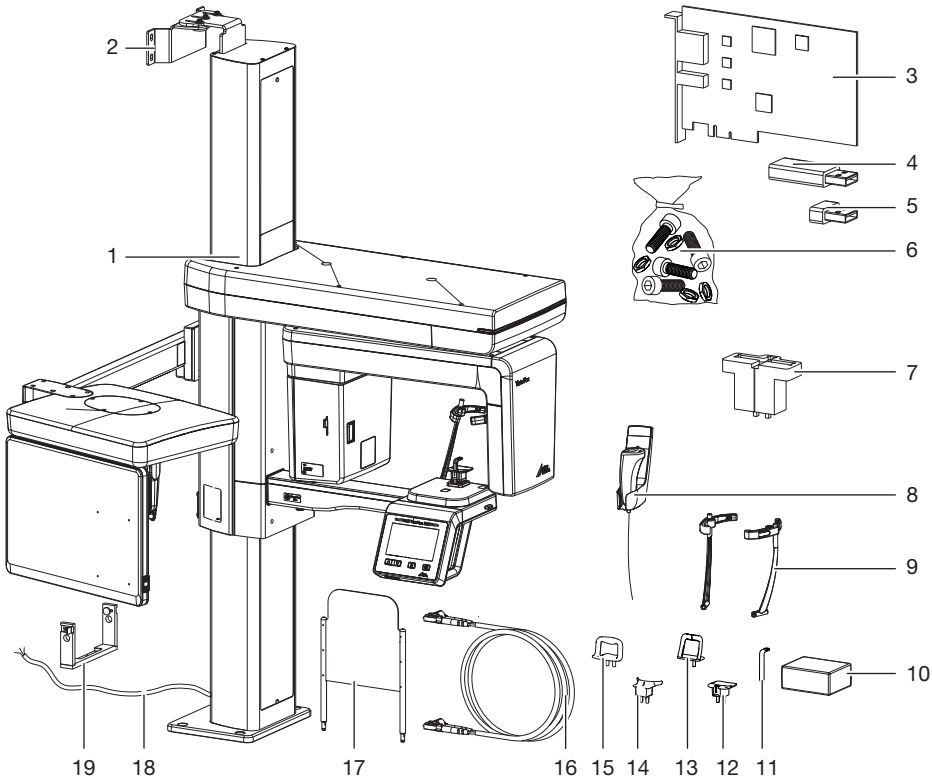

- |    |   |    |                                       |
|----|---|----|---------------------------------------|
| 1  | 3D, Ceph and panoramic X-ray unit                     | 11 | Bite block                            |
| 2  | Wall bracket  | 12 | Holder for bite block                 |
| 3  | Frame grabber card                                    | 13 | Chin holder for maxillary joint image |
| 4  | USB dongle  | 14 | Chin support for edentulous jaws      |
| 5  | USB stick containing device-specific calibration data | 15 | Chin holder for sinus image           |
| 6  | Small parts   | 16 | Fiber optic cable                     |
| 7  | Pano test phantom holder                              | 17 | Carpus plate                          |
| 8  | Exposure switch (with holder)                         | 18 | Mains cable for permanent connection  |
| 9  | Head supports with cushion                            | 19 | Ceph test phantom holder              |
| 10 | Hygienic protective covers for bite block             |    |                                       |

### 3.3 Scope of delivery

The following items are included in the scope of delivery (possible variations due to country-specific requirements and/or import regulations):

ProVecta 3D Prime . . . . . A7750

- Fiber optic cable 10 m / 33 ft
- Exposure switch and holder
- Holder for bite block
- Bite blocks (3x)
- Chin support for edentulous jaws
- Chin holder for maxillary joint image
- Chin holder for sinus image
- Head supports with cushion
- Wall bracket top (16 in)
- Hygienic protective covers for bite block (100 pieces)
- Small parts set (e. g. screws, nuts)
- Various housing parts
- Operating instructions
- Installation instructions
- PCI Express frame grabber card
- USB dongle
- USB stick containing device-specific calibration data

ProVecta 3D Prime Ceph . . . . . A7850

- Fiber optic cable 10 m / 33 ft
- Exposure switch and holder
- Holder for bite block
- Bite blocks (3x)
- Chin support for edentulous jaws
- Chin holder for maxillary joint image
- Chin holder for sinus image
- Head supports with cushion
- Top wall bracket set, long
- Hygienic protective covers for bite block (100 pieces)
- Small parts set (e. g. screws, nuts)
- Various housing parts
- Operating instructions
- Installation instructions
- PCI Express frame grabber card
- USB dongle
- USB stick containing device-specific calibration data
- Carpus plate



If the mains cable of this unit is damaged it must only be replaced by an original mains cable from the manufacturer.

### 3.4 Optional items

The following optional items can be used with the device:

Top wall bracket set, long (wall/wall installation) . . . . .	A7764
Bottom wall bracket set, long (wall/wall installation) . . . . .	A7755
Fiber optic cable 5 m . . . . .	A7757
Fiber optic cable 20 m . . . . .	A7758
Stand . . . . .	A7815
Silicone pads for head support Plus . . . .	A7803

#### Acceptance and consistency check

2D X-ray Pan phantom set . . . . .	A7556
Consistency check test phantom 3D set .	A7759
Acceptance test phantom 3D set . . . . .	A7760
Ball phantom . . . . .	A7330
2D X-ray test phantom holder . . . . .	A7366

#### ProVecta 3D Prime only

Bottom wall bracket set, 16 inch, short (wall/wall installation) . . . . .	A7754
--	-------

#### ProVecta 3D Prime Ceph only

Set of silicone pads Ear rods and nose support . . . . .	A7910
--	-------

### 3.5 Consumables

The following materials are consumed during operation of the device and must be re-ordered:

Hygienic protective cover bite block (100 pieces) . . . . .	A7395
Silicone pads for head support Plus . . . .	A7803

#### Cleaning and disinfection

Monarch surface disinfection wipes (hundred pcs. - 7" x 9") . . . . .	H6171
Monarch enzymatic cleaner (84.5 oz. bottle) . . . . .	H6201



Information on replacement part is available at the portal for authorized specialist dealers:

*www.airtechniques.com.*

#### ProVecta 3D Prime Ceph only

Set of silicone pads Ear rods and nose support . . . . .	A7910
--	-------

## 4 Technical data

### Electrical data for the device

Nominal voltage	V AC	200 - 240
Frequency	Hz	50/60
Protection class		I
Operating mode X-ray tube		S6 = 6.3% 320 s duty cycle 20 s / 5 min (switch-on/switch-off time)
Operating mode height adjustment		S3 = 9% duty cycle 1 min / 9 min (switch-on/switch-off time)
Rated power	W	170
Maximum power	kVA	2.2
Fuses* (2 pcs.)	A	T 10.0 AH / 250 V~ (IEC 60127-2, Sheet 5)

\* The fuses may only be replaced by Air Techniques or by a body authorized by Air Techniques.

### Classification

Medical Device Class (MDR)	IIb
FDA classification (CFR Title 21)	II

### General technical data

		ProVecta 3D Prime	ProVecta 3D Prime Ceph
Dimensions (W x D)	mm	572.5 x 1181 ± 12	1940.8 x 1251 ± 12
	in	22.54 x 46.50 ± 0.47	76.41 x 49.25 ± 0.47
Height	mm	1406 - 2206	1406 - 2206
	in	55.35 x 86.85	55.35 x 86.85
Weight	kg	180	202
	lbs	397	445

### Ambient conditions during storage and transport

Temperature	°C	-10 to +60
	°F	14 to 140
Relative humidity	%	10 - 75
Air pressure	hPa	860 - 1060

### Ambient conditions during operation

Temperature	°C	10 - 35
	°F	50 - 95
Relative humidity	%	30 - 75
Air pressure	hPa	860 - 1060

### X-ray emitter

Model		DG-07E22T2
Rated power	kW	1.6 (for 1 s)
Type of high-voltage generator		Inverter

**X-ray emitter**

Nominal voltage, high-voltage generator	kV	60 - 99 ( $\pm 10\%$ )
Nominal current, high voltage generator	mA	4 - 16 ( $\pm 10\%$ , max. 75 kV 16 mA, max. 99 kV 10 mA)
Cooling, high-voltage generator		Automatic monitoring Shut-off at $\geq 60^\circ\text{C}$
Additional filtration	mm Al in Al	1.5 + 3.0 (added automatically for CBCT) 0.06 + 0.12 (added automatically for CBCT)
Inherent filtration	mm Al in Al	0.8 0.03
Total filtration	mm Al in Al	2.5 + 3.0 (added automatically for CBCT) 0.09 + 0.12 (added automatically for CBCT)
X-ray tube model		D-052SB / Canon (Toshiba)
Focal spot size as per IEC 60336 X-ray tube	mm in	0.5 0.02
Anode angle*	$^\circ$	5
Anode heat capacity	kJ	35
Pulse/break ratio		1:60 or more
Duration of radiation exposure	s	0.5 - 20
Maximum current-time product per hour	mAs	960 (at 75 kV/16 mA)

\*The reference axis is the perpendicular of the X-ray exit window at the level of the side marker for the focal point on the cover of the X-ray emitter

#### 4.1 X-ray tube performance data

- Maximum deviation of the peak voltage from the displayed value  $\pm 10\%$
- Maximum deviation of the tube current from the displayed value  $\pm 20\%$
- Maximum deviation of the exposure time from the displayed value  $\pm 10\%$
- The device complies with the standards IEC 60601-1, IEC 60601-1-3 and IEC 60601-2-63.
- The lowest possible load factor is obtained with a combination of the settings 60 kV and 4 mA.

### Maximum Rating Charts

DC (Center Grounded)

Constant potential high-voltage generator

Nominal Focus Spot Value: 0.5

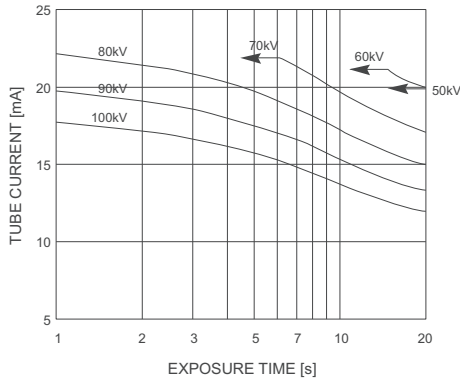

### Emission and Filament Characteristics

Constant potential high-voltage generator

Nominal Focus Spot Value: 0.5

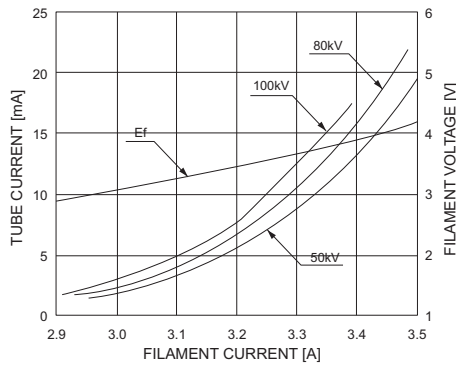

### Anode Thermal Characteristics

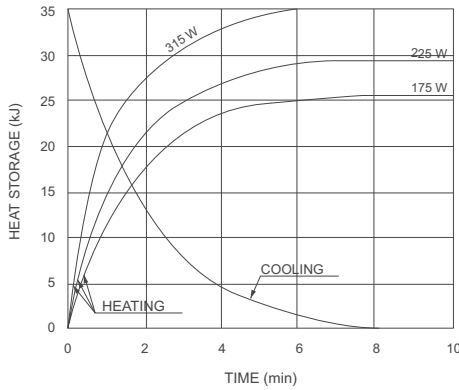

Detector		Pano/CBCT	Cephalometric projections
Brand		Xmaru1404CF	Xmaru 2602CF
Type		CMOS photodiode array	
Pixel size	µm	49.5 99 (2x2 binning) 198 (4x4 binning)	100 200 (2x2 binning)
Sensor size	mm in	230 x 160 x 26 9.06 x 6.30 x 1.02	279 x 110 x 20 10.98 x 4.33 x 0.79
Active surface area	mm in	135.8 x 36.4 5.35 x 1.43	259.2 x 15.6 10.20 x 0.61
Frame rate	fps	53.5 107 (2x2 binning) 308 (4x4 binning)	320
Gray scales	bit	14	

Exposure mode	FDD mm in	FOD mm in	ODD mm in	Image capture scale (magnification factor)
CBCT	600 23.62	428.6 16.87	171.4 6.75	-
Panorama	600 23.62	477.7 18.81	122.3 4.81	1.26
Cephalometric projections	1745 68.70	1524 60.00	221 8.70	1.14

FDD: distance from focal spot to detector

FOD: distance from focal spot to object

ODD: distance from object to detector (ODD = FDD - FOD)

Image capture scale = FDD/FOD



**Electromagnetic compatibility (EMC)  
Interference emission measurements**

High-frequency emissions in accordance with CISPR 11	Group 1
Interference voltage at the power supply connection CISPR 11:2009+A1:2010	Class A
Electromagnetic interference radiation CISPR 11:2009+A1:2010	Class A
Emission of harmonics IEC 61000-3-2:2005+A1:2008+A2:2009	Class A
Voltage changes, voltage fluctuations and flicker emissions IEC 61000-3-3:2013	Compliant

**Electromagnetic compatibility (EMC)  
Interference immunity measurements on cover**

Immunity to interference by discharge of static electricity IEC 61000-4-2:2008 ± 8 kV contact ± 2 kV, ± 4 kV, ± 8 kV, ± 15 kV air	Conforms
Immunity to interference by high-frequency electromagnetic fields IEC 61000-4-3:2006+A1:2007+A2:2010 3 V/m 80 MHz - 2.7 GHz 80 % AM at 1 kHz	Conforms
Immunity to interference by near fields of wireless HF communication devices IEC 61000-4-3:2006+A1:2007+A2:2010 See Table on immunity to interference table by near fields of wireless HF communication devices.	Conforms

**Immunity to interference levels by near fields of wireless HF communication devices**

Radio service	Frequency band MHz	Test level V/m
TETRA 400	380 - 390	27
GMRS 460 FRS 460	430 - 470	28
LTE band 13, 17	704 - 787	9
GSM 800/900 TETRA 800 iDEN 820 CDMA 850 LTE band 5	800 - 960	28

<b>Immunity to interference levels by near fields of wireless HF communication devices</b>		
<b>Radio service</b>	<b>Frequency band MHz</b>	<b>Test level V/m</b>
GSM 1800 CDMA 1900 GSM 1900 DECT LTE bands 1, 3, 4, 25 UMTS	1700 - 1990	28
Bluetooth WLAN 802.11 b/g/n RFID 2450 LTE band 7	2400 - 2570	28
WLAN 802.11 a/n	5100 - 5800	9

<b>Electromagnetic compatibility (EMC)</b>		
<b>Interference immunity measurements on supply input</b>		
Immunity to interference by rapid transient bursts – AC voltage grid IEC 61000-4-4:2012 ± 2 kV 100 kHz repetition frequency		Conforms
Immunity to interference, line-line IEC 61000-4-5:2005 ± 0.5 kV, ± 1 kV		Conforms
Immunity to interference by surges, line-earth IEC 61000-4-5:2005 ± 0.5 kV, ± 1 kV ± 2 kV		Conforms
Immunity to interference, line-conducted disturbances induced by high-frequency fields – AC voltage grid IEC 61000-4-6:2013 3 V 0.15 - 80 MHz 6 V ISM frequency bands 0.15 - 80 MHz 80 % AM at 1 kHz		Conforms
Immunity to interference due to voltage dips, short interruptions and voltage fluctuations IEC 61000-4-11:2004 0% U <sub>T</sub> for 0.5 cycle 0% U <sub>T</sub> for 1 cycle 70% U <sub>T</sub> for 25/30 cycles (50/60 Hz) 0% U <sub>T</sub> for 250/300 cycles (50/60 Hz)		Conforms



## 4.2 Dimensions

### ProVecta 3D Prime

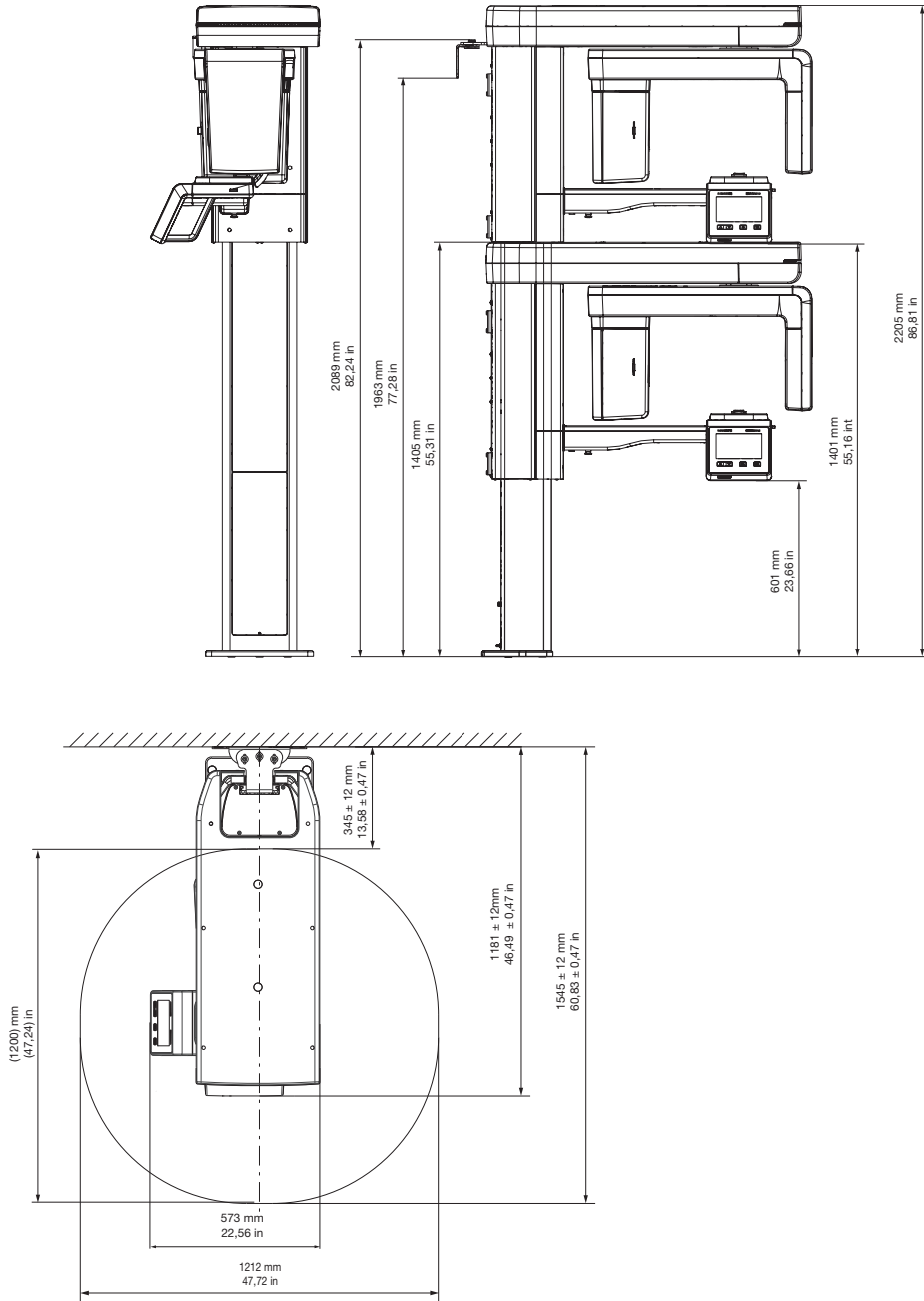



EN-US

# ProVecta 3D Prime Ceph

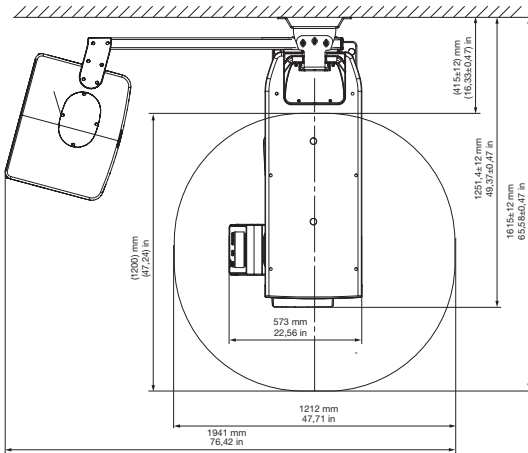
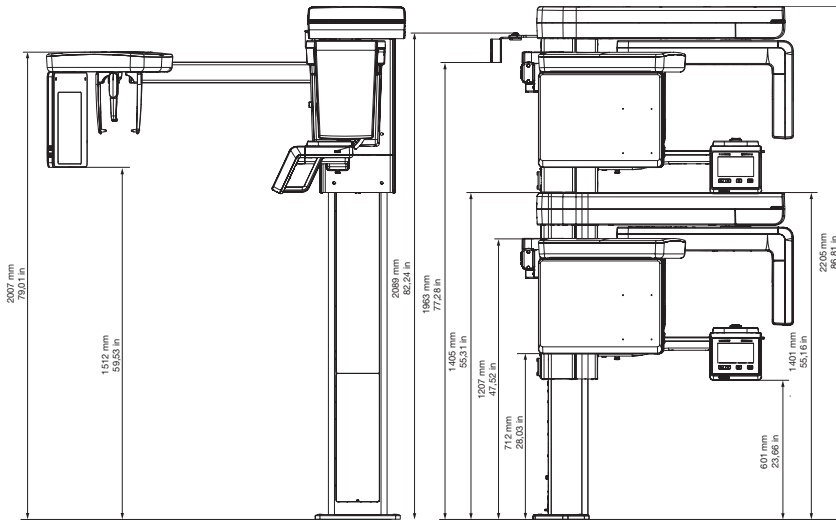

### 4.3 Model identification plate

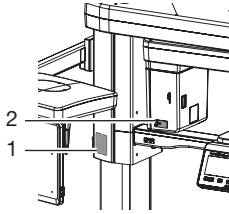

- 1 Type plate of the unit
- 2 Type plate of the X-ray tube

### 4.4 Conformity assessment

This device has been subjected to conformity acceptance testing in accordance with the current relevant guidelines of the European Union. This equipment conforms to all relevant requirements.

## 5 Function

### 5.1 3D and panoramic X-ray unit

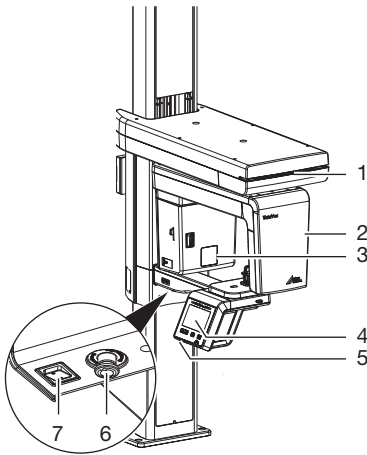

- 1 Status LED
- 2 Rotating unit
- 3 X-ray tube
- 4 User interface
- 5 Memory card slot
- 6 Emergency stop switch
- 7 On/off switch

Similar to computer tomography or magnetic resonance tomography, sectional images can be generated with CBCT. With CBCT, an X-ray tube and an imaging sensor opposite it rotate around a seated or standing patient. The X-ray tube rotates through 180°-540° and emits a conical X-ray beam. The X-rays pass through the region under investigation and are measured for image generation by a detector as an attenuated grey scale X-ray image. Here, a large series of two-dimensional individual images is acquired during the revolution of the X-ray tube. Using a mathematical calculation on the rotating image series via a reconstruction computer, a grey value coordinate image is generated in the three spatial dimensions. This three-dimensional coordinate model corresponds to a volume graphic that is made up of individual voxels. This volume can be used to generate sectional images (tomograms) in all spatial dimensions as well as 3D views. The X-ray job is started via the imaging software and activated via the touch screen.

### 5.2 Cephalometric X-ray unit

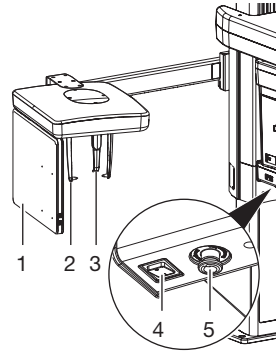

- 1 Sensor (Ceph)
- 2 Ear rods with holder
- 3 Nose support
- 4 On/off switch
- 5 Emergency stop switch

Recording digital cephalometric radiographs, the patient's head is scanned line by line with a fan-shaped, flat X-ray beam.

The X-ray job is started via the imaging software and activated via the touch screen.

### 5.3 Status LED

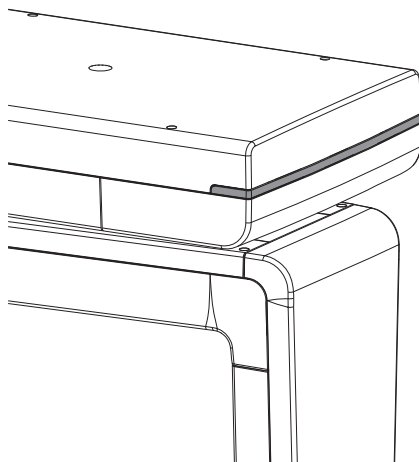

The status LED uses different colors to display the different operating modes:

- Blue: unit ready for operation
- Green: unit ready to acquire image
- Yellow: X-ray beam active

## 5.4 Positioning aids

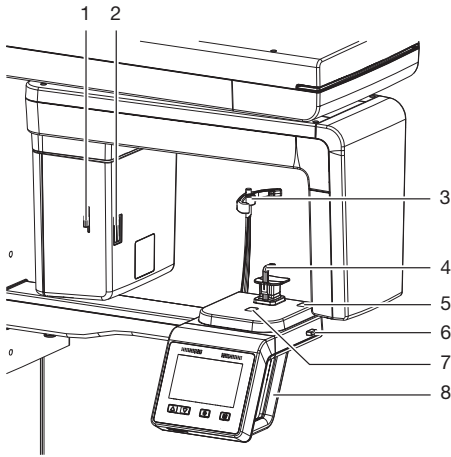

- 1 Lever for positioning the Frankfurt plane positioning beam
- 2 Frankfurt plane of the X-ray positioning beam
- 3 Head supports with cushion
- 4 Positioning aid, e. g. chin support with bite block
- 5 Upper canine positioning beam
- 6 Lever for positioning the upper canine positioning beam
- 7 Mid-sagittal positioning beam
- 8 Grips

The applied parts in accordance with IEC 60601-1 are:

- Grips
- Head supports with cushion
- Positioning aids (e.g. bite block and mounting for bite block, chin support for edentulous patients)

### Description of the positioning aids

The positioning aids are used to correctly position the patient in the unit. The appropriate positioning aid is selected according to the selected image. The head supports gently keep the head of the patient in place.

### Panoramic

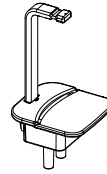

Bite block and adapter bite block

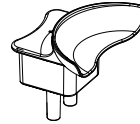

Chin holder for edentulous jaws

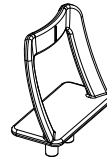

Chin holder for maxillary joint image

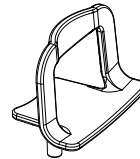

Chin holder for sinus image

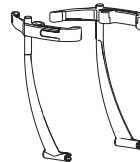

Head supports with cushion

## 5.5 Positioning aids for cephalometric projections

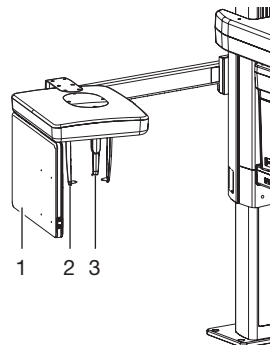

- 1 Sensor (Ceph)
- 2 Ear rods with holder
- 3 Nose support

**Cephalometric projections**

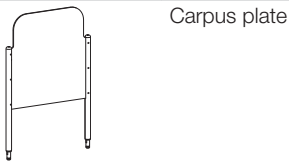
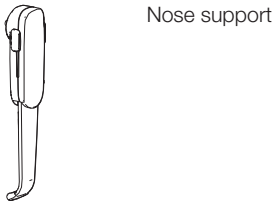
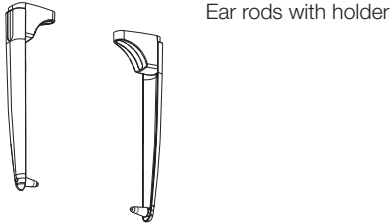

The applied parts in accordance with IEC 60601-1 for the cephalometric unit are:

- Nose support
- Ear rods with holder
- Carpus plate

**5.6 Exposure button**

**Exposure switch**

The exposure switch is used to trigger the prepared image acquisition and start the X-ray exposure. The LED indicates the status of the unit, as does the LED on the unit.

- Green: unit ready for recording
- Yellow: X-ray beam active

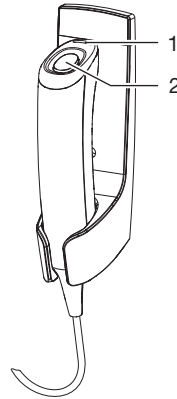

- 1 Indicator lamp (LED)
- 2 Exposure button

**5.7 Memory card slot**

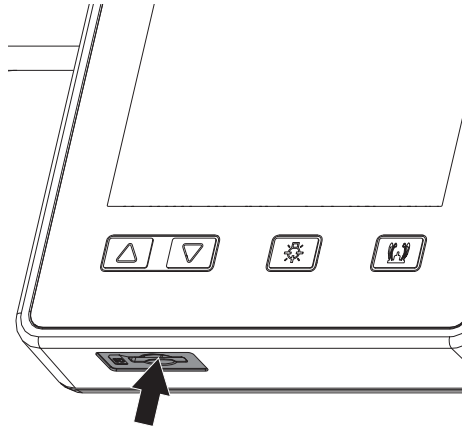

The unit has a slot for a memory card. The slot is needed for service purposes only.

**5.8 Sensor window**

The active sensor surface is indicated by the markers in the corners of the sensor window. The cross indicates the geometric mid-point of the active sensor surface.



### Panoramic X-ray device

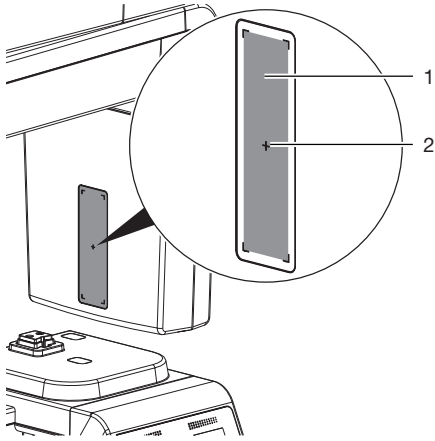

- 1 Active sensor surface
- 2 Geometric mid-point of the active sensor surface

### Cephalometric X-ray unit

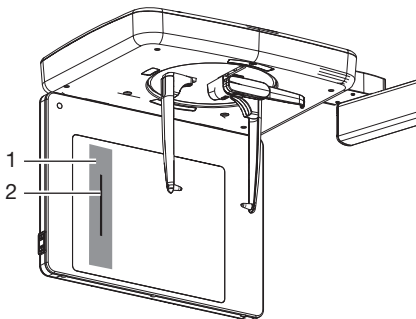

- 1 Line sensor housing
- 2 Active sensor surface

-  Only qualified specialists or persons trained by Air Techniques may install, connect, and commission the unit.

## 6 Requirements

### 6.1 Installation/setup room

The room chosen for set up should fulfil the following requirements:

- Closed, dry room.
- It should not be a room made for another purpose (e.g. boiler room or wet cell).
- There should be no major fields of interference (e.g. strong magnetic fields) present that can interfere with the proper operation of the unit.
- The required environmental conditions are met (refer to "Technical Data" in the operating instructions).

Portable and mobile HF communication appliances can interfere with the effectiveness of electrical medical devices.

- › Do not stack the unit next to or together with other appliances.
- › If, however, this unit is operated next to other units or stacked with other units, monitor the unit carefully in the configuration selected in order to ensure normal operation.

 **WARNING**  
**Risk of explosion due to inflammation of combustible materials**

- › Do not use the unit in rooms in which combustible mixtures may be present, e.g. in operating rooms.

#### Radiation protection

- › Comply with all applicable X-ray protection regulations and X-ray protection measures.
- › Use the prescribed X-ray protection equipment.
- › In order to reduce the level of X-ray exposure, we recommend the use of bismuth, lead shielding or protective aprons, especially for children and teenagers.

- › The persons operating the equipment must keep away from the X-ray unit while the exposure is being taken. The minimum distance required by the law must be maintained.
- › Children and pregnant women must consult a doctor before recording an X-ray image.
- › No person other than the patient is permitted to be present in the radiation room without X-ray protection measures. In exceptional circumstances another person may be present to provide assistance, but this must not be a member of the surgery staff. When the exposure is being taken, make sure that you maintain visual contact with the patient and the unit and keep talking to the patient.
- › The radiation room must be lockable to prevent entry by unauthorized persons.
- › If a fault occurs, abort the exposure immediately by releasing the trigger button.

#### Information about electrical connections

 **WARNING**  
**Electric shock due to incorrectly connected device**

- › Never install a mains plug instead of the fixed connection.

- › Make sure that the electrical connections to the mains power supply are established in accordance with current valid national and local regulations and standards governing the installation of low voltage units in medical facilities.
- › The connection to the mains supply must be a fixed connection that cannot be disconnected without the use of tools. Plug-in connections (power outlet/plug) are not permissible.
- › Install an all-pole disconnection unit (all-pole switch) in the electrical connection to the mains power supply. This must include the creepage distances and air gaps defined in IEC 61058-1 for a mains voltage peak of 4 kV. It must be possible to secure the disconnect switch so that it cannot be inadvertently switched back on again.

-  The disconnection unit (switch) must be easily and safely accessible.

- › Note the current consumption of the devices that are to be connected.

## 6.2 System requirements for the reconstruction computer

A reconstruction PC with increased requirements is required to operate the unit. In addition, a direct connection via fiber optic cable is required between the reconstruction PC and the unit.



The processor and graphics board must meet the specifications and system requirements to ensure a faultless reconstruction. Should these requirements not be met, Air Techniques does not provide any guarantee for faultless reconstruction.

CPU:	≥ Intel Xeon E5-1607, 3 GHz ≥ Intel Core i7-6700, 3.4 GHz
RAM:	≥ 16 GB DDR3-1600
Operating systems:	Microsoft Windows 10, 64-bit (Pro or higher)
Hard disk:	– For reconstruction: ≥ 500 GB SSD – Additionally for the database (applies to single workstation installation only): the database memory requirements of the database depend on the number of images taken at the practice. (Camera image: approx. 1 MB, X-ray image: approx. 2 MB - 10 MB, CBCT: 200 - 400 MB)
Interface:	1 PCI Express slot Gen2 x4 USB socket Gigabit Ethernet (applies to multi-station installation only)
Graphics board:	NVIDIA GeForce GTX970 4 GB NVIDIA GeForce GTX1060 6 GB NVIDIA GeForce GTX1070 8 GB NVIDIA GeForce GTX1080 8 GB NVIDIA GeForce GTX1660Ti 6 GB NVIDIA GeForce RTX2070 8 GB NVIDIA Quadro P2000 5 GB NVIDIA Quadro RTX4000 8 GB
Diagnostic monitor:	In accordance with DIN 6868-157, room category 5 or 6 (depending on the requirements)
Software:	VisionX version 2.4 or higher (order number: E7300)

- › When connecting the unit to other devices, e. g. a PC system, comply with the requirements set out in section 16 of IEC 60601-1 (EN 60601-1).
- › When setting up the PC system in the vicinity of the patient:  
Only connect components (e.g. computer, monitor, printer) that comply with the standard IEC 60601-1 (EN 60601-1).
- › When setting up the PC system outside of the vicinity of the patient:  
Connect components (e.g. computer, monitor, printer) that comply at least with the IEC 60950-1 (EN 60950-1) standard.



For the system requirements of the computer systems, visit the download area at [www.airtechniques.com](http://www.airtechniques.com) (document no. E7201).

## 7 Installation



### NOTICE

#### Danger to components due to electrostatic discharge (ESD)

- › Establish equipotential bonding between the person carrying out the work and the surroundings, e.g. via a wrist strap that is connected to the basic unit. Here, the basic unit must be earthed via the earth terminal.



### NOTICE

#### Risk of equipment damage

Do not push or pull the unit during installation by holding on to the C-shaped arm or the handle for the patient.

- › Move the unit carefully and only grip it by the telescopic column.

### 7.1 Checks before unpacking

- › Visually inspect the packaging for damage.
- › Check to see if the Shockwatch display has been activated.

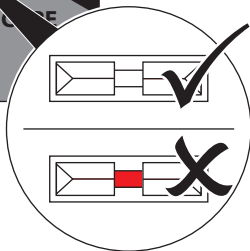
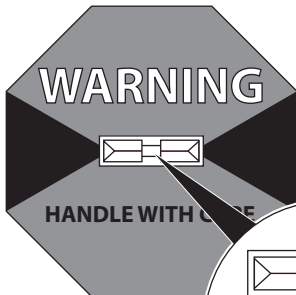

- › Check to see if the Tiltwatch display has been activated.

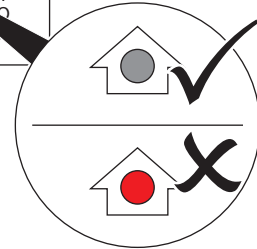
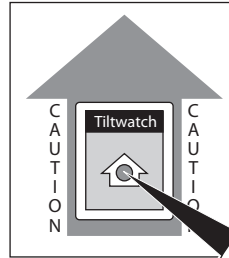

- › If the Shockwatch or Tiltwatch display is activated or there is damage to the packaging, do not unpack the unit; contact the shipping company.

### 7.2 Unpacking the unit

The unit is supplied on a special pallet and is split into several parts on delivery. We recommend using two persons to transport each part individually from the delivery location to the installation site. To ensure that the parts are still protected during transport, do not remove the foam packaging, protective films etc.

- › Remove the lid from the outer carton.
- › Remove the outer carton.

- › Take out the accessories carton, the Ceph part and the carton with cross-member and rotating unit and place them to one side.

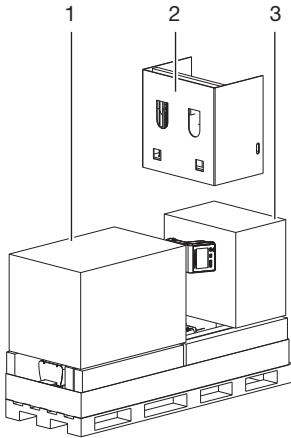

- 1 Carton with cross-member and rotating unit
- 2 Ceph part
- 3 Accessories carton

- › Take out the cartons with the trim parts and covers and place to one side.  
The cartons marked *Components inside* contain parts or accessories.  
Cartons that are unmarked are empty and are provided only for protection and to stop other items moving around during transport.

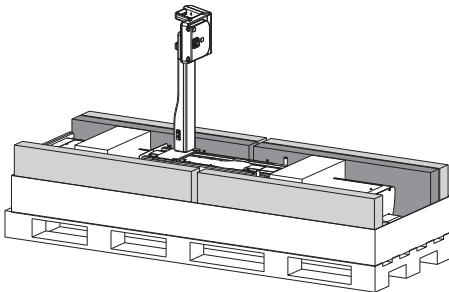

- › Remove the foam parts from the ends of the column.

- › Fold the outer carton away to the outside.

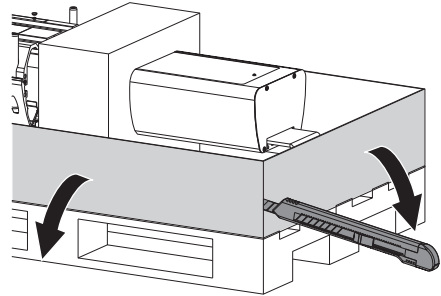

- › Take out the column with column slide and transport it to the installation site.

## 7.3 Setting up the unit

### Installation variants for ProVecta 3D Prime

	Standard Without underfloor heating	Standard With under- floor heating	Walls not able to take the load	Standard with addi- tional wall bracket at the bottom
Weight in kg	180	180	240 (with foot)	180
Top wall bracket	x	x	x	x
Absorption of tensile forces by the wall at the top wall bracket in N	1400	1400	800	1260
Absorption of tensile forces by each screw and anchor at the top wall bracket in N, 4 screws required	350	350	200	315
Bottom wall bracket		x		x
Absorption of tensile forces by the wall at the bottom wall bracket in N		140		140
Absorption of tensile forces by each screw and anchor at the bottom wall bracket in N, 4 screws required		35		35
Screwed to the floor with a bottom plate, 4 screws required	x			x
Absorption of tensile forces by each screw and anchor at the bottom plate in N	135			135
Foot with integrated bottom plate			x	

**Installation variants for ProVecta 3D Prime Ceph**

	<b>Standard Without underfloor heating</b>	<b>Standard With under- floor heating</b>	<b>Walls not able to take the load</b>	<b>Standard with addi- tional wall bracket at the bottom</b>
Weight in kg	202	202	262 (with foot)	202
Top wall bracket	x	x	x	x
Absorption of tensile forces by the wall at the top wall bracket in N	3200	3200	2000	2800
Absorption of tensile forces by each screw and anchor at the top wall bracket in N, 4 screws required	800	800	500	700
Bottom wall bracket		x		x
Absorption of tensile forces by the wall at the bottom wall bracket in N		320		280
Absorption of tensile forces by each screw and anchor at the bottom wall bracket in N, 4 screws required		80		70
Screwed to the floor with a bottom plate, 4 screws required	x			x
Absorption of tensile forces by each screw and anchor at the bottom plate in N	400			400
Foot with integrated bottom plate			x	

### Requirements

- Easily accessible electrical connections
- The electrical connections comply with the requirements (see "4 Technical data")

### Tools required:

- Hexagon key SW13
- Torx key T20
- Torx key T45
- Allen key size SW 3
- Allen key size SW 4
- Allen key size SW 5
- Allen key size SW 6
- Spirit level (max. length 26–30 cm)

### Installing the column with column slide

- › Keep the column in the foam parts and lay it down in front of the wall to position it.



### CAUTION

**The unit could tip over and cause injuries.**

- › Position the unit or secure it appropriately such that it cannot tip over.

- › Place some foam from the packaging under the upper part of the column. This will make it easier to install the wall mounting bracket. Alternatively, the wall mounting bracket can be attached to the standing column.

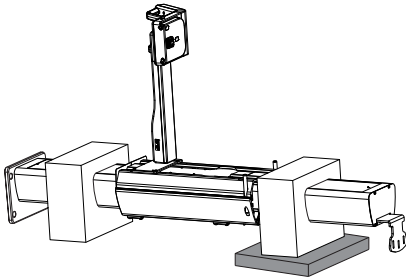

- › Attach the upper wall mounting bracket (refer to the accessories carton) to the column.

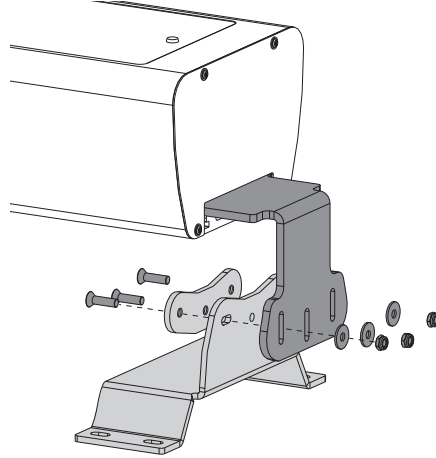

- › Set up the column with the aid of the transport grips.
- › Remove the lower housing cover (see "Removing the housing cover").
- › Remove the lower transport grip.
- › If the column with the column slide cannot be screwed to the floor (e.g. in the case of under-floor heating) or of the wall lacks the appropriate strength, then the lower wall mounting bracket also needs to be installed.
- › Attach the retaining plate to the column.

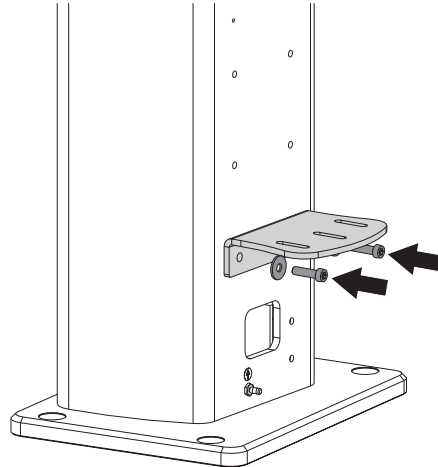



- › Secure the wall mounting bracket to the retaining plate.

Here, the wall mounting bracket can be attached in several different mounting positions.

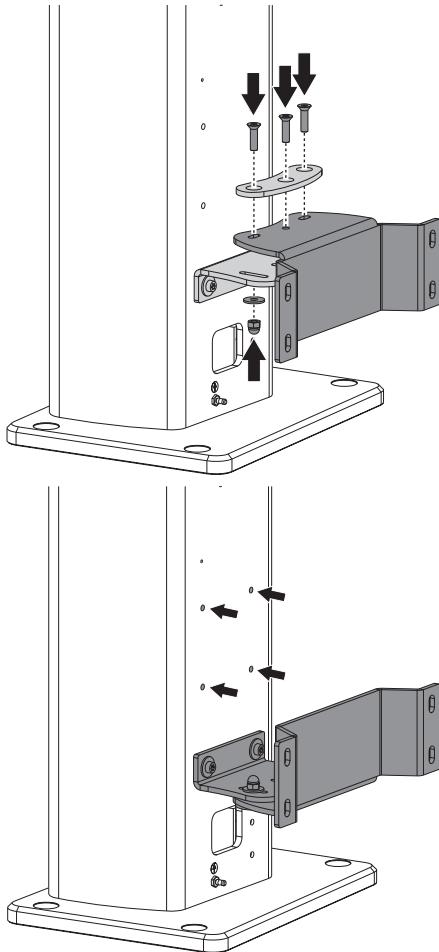
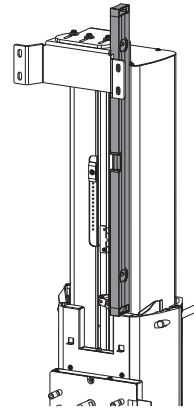

Fig. 1: Possible mounting position for the lower wall mounting bracket

- › Roughly align the column.



- › Mark the anchor holes centrally on the wall mounting bracket(s).
- › Take the column with wall mounting bracket away off the wall.
- › Drill holes for the anchors and insert the anchors.
- › Attach the column with the wall mounting bracket to the wall.  
For attachment, use screws with washers (max.  $\varnothing$  of the washer: 20 mm).

- › Roughly align the column again.

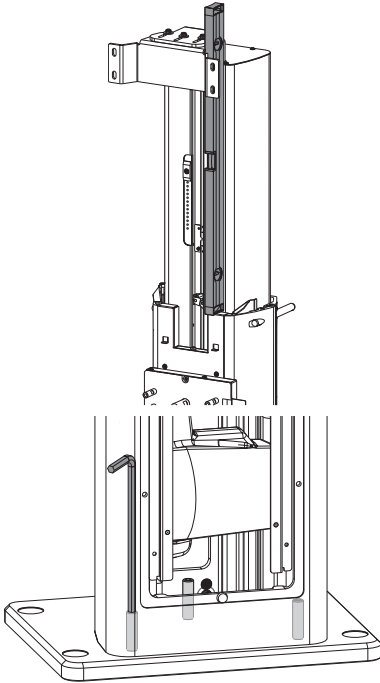

- › Drill the anchor holes for the floor plate.  
It is possible to drill through the holes in the floor plate (max. drill bit diameter 10 mm).
- › Secure the base plate with four screws.
- › Remove the upper transport grip from the column.

#### Installing the stand (optional)

Requirements:

- ✓ The top wall bracket is mounted on the column
- ✓ The column is upright
- ✓ The bottom transport handles have been removed
- › Set the column on the stand.

- › Attach the column with four screws and washers to the stand.

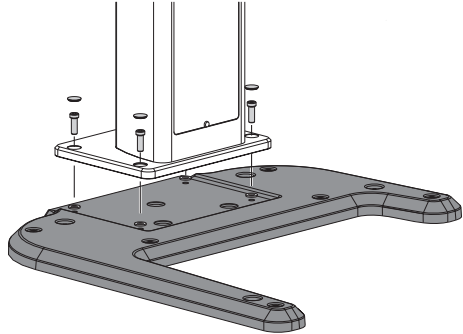

- › Roughly align the device via the floor stand.

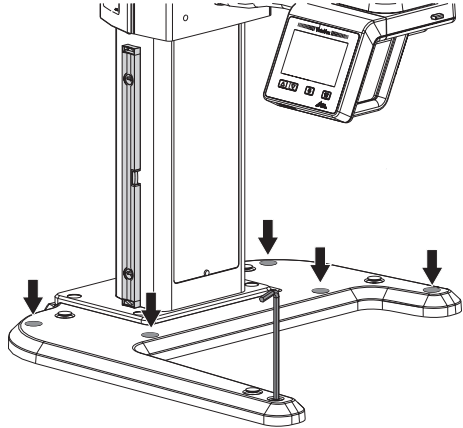

- › Place the stand cover on the stand.

#### Installing the cross-member with rotating unit



Fiber optic cables are sensitive to dirt and dust. For this reason, do not remove the protective caps from the cable ends and plug sockets until just before you connect the cable. If the end of the cable gets dirty during connection then it will need to be cleaned. We recommend using a specialty cleaner for fiber optic cables (LC plug connections). Refer to the manufacturer's information when doing this.

Fiber optic cables are also sensitive to kinking. For this reason, do not to bend the cable at a sharp angle, but route it around corners with a radius of  $\geq 80$  mm.

- › Place the carton with cross-member and rotating unit in front of the column.

- › Remove the carton.  
Remove enough of the foam parts such that the cross-member with rotating unit can be taken out.  
Do not remove the protective film from the column. The protective film protects the column against damage during installation of the cross-member with rotating unit.
- › Mount the transport grips on the cross-member.

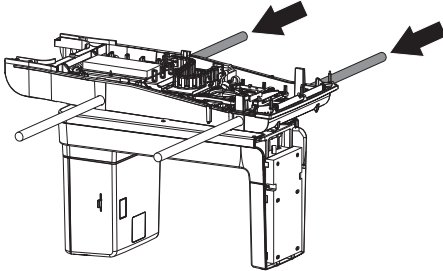

- › Detach the cable from the column slide in front of the mounting face and reroute it to the rear.

- › Check to make sure that the mounting faces on the cross-member and on the column slide are clean and free of damage.

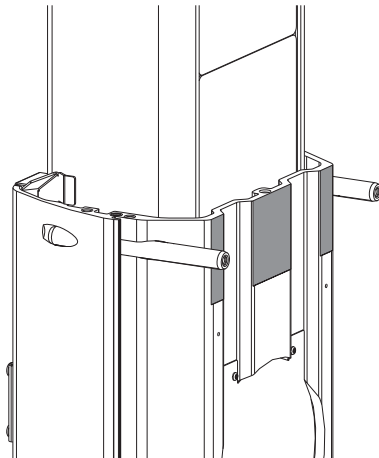
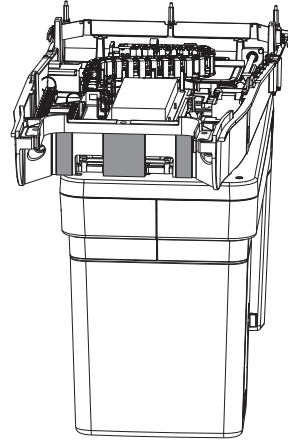

- › Check all required threads for ease of movement (refer to the next steps below).

**i** During the following steps, maintain the correct sequence when tightening the screws.

- › Use the transport grips to lift the cross-member with rotating unit out the foam parts and place the cross-member on the column slide. Here, the pins serve as centering aids/guides.

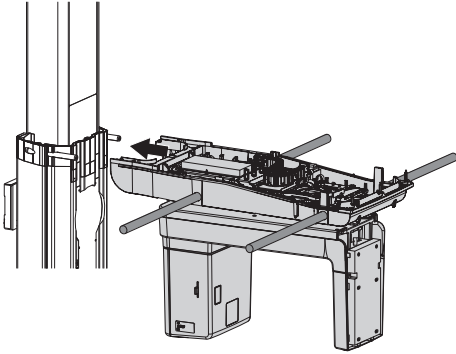

**NOTICE**

**Equipment damage due to trapped cables**

- › When positioning the crossmember on the column slides, make sure that no cables are trapped.
- › Position the cross-member with rotating unit such that it makes full contact with the column slide.

- › One person secures the cross-member with rotating unit, while a second person attaches the cross-member with the two bushings and screws to the column slide. Tighten the screws on the locating pins by hand.

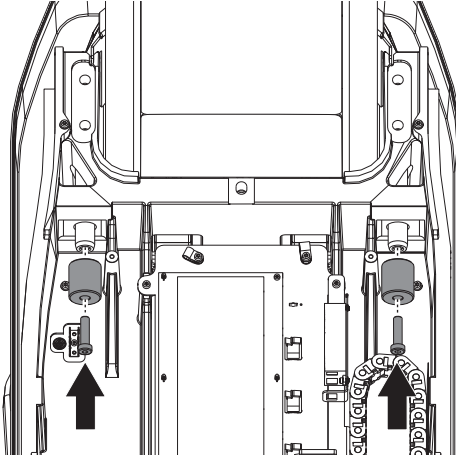

- › Tighten the rear four screws by hand.

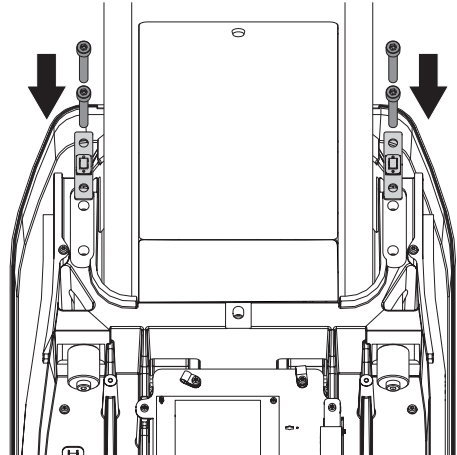

- › Position the assembly aid for the locating screw and carefully tap in the locating screw with a hammer until it reaches the stop.

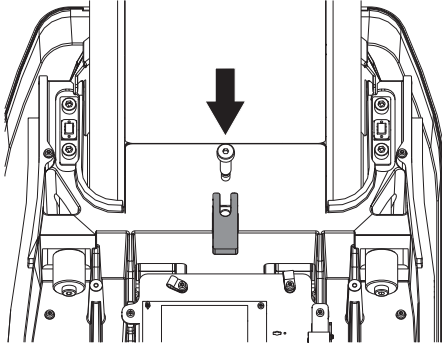

- › Remove the assembly aid.

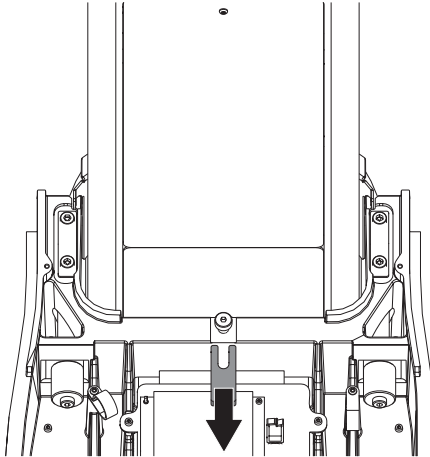

- › Tighten the locating screw by hand. To do this, it may be necessary to exert some pressure on the screw.

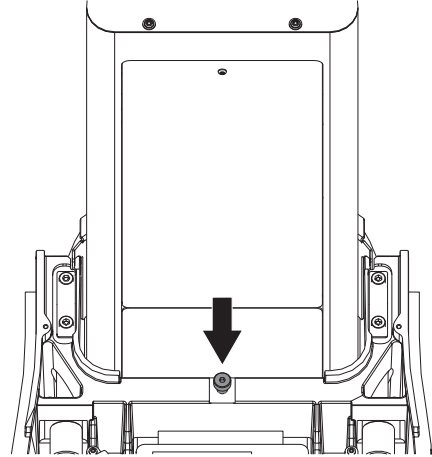

- › Check to make sure that the cross-member makes even contact on the column slide. If the cross-member does not make even contact, check all screws and correct them as required.

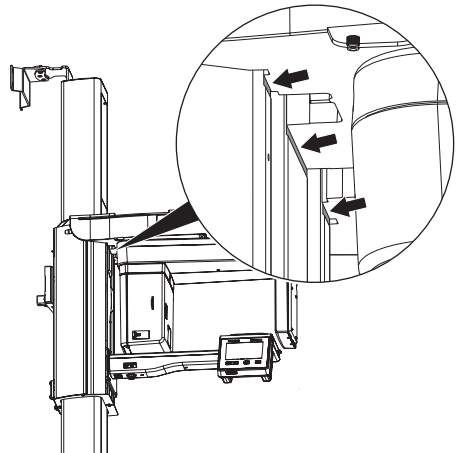

- › Once the cross-member is making even contact, start by tightening the two screws on the locating pins, then tighten the four screws on the column slide, and finally tighten the locating screw.

- › Check the alignment of the cross-member with a spirit level.  
Correct its position with the adjustable feet on the floor plate. To do this, it may be necessary to loosen the screws on the floor plate and on the wall mounting brackets.

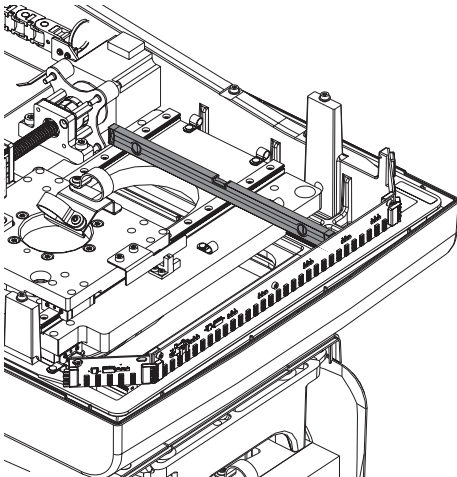
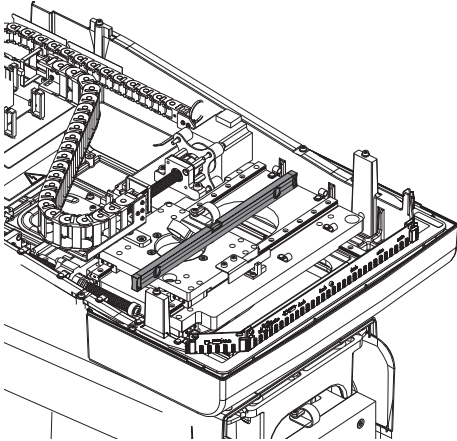

- › Remove the transport grips.
- › Pull off the protective film from the column.

- › Mount the lever for positioning of the Frankfurt plane beam localizer (in the accessories) to the rotating unit.

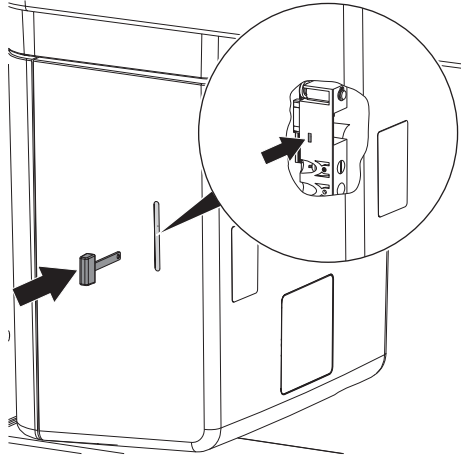

#### Installing the Ceph arm

- › Attach the Ceph arm to the column.

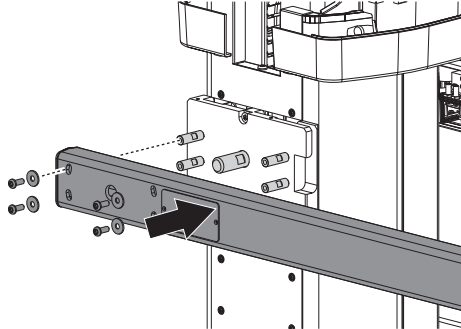

**Connecting the cross-member**

- › Route the cables from the column slide through the cable attachments.

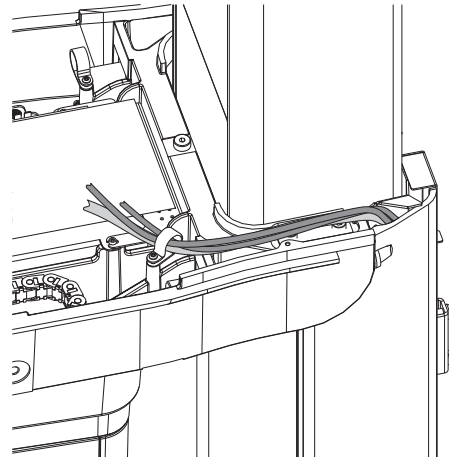
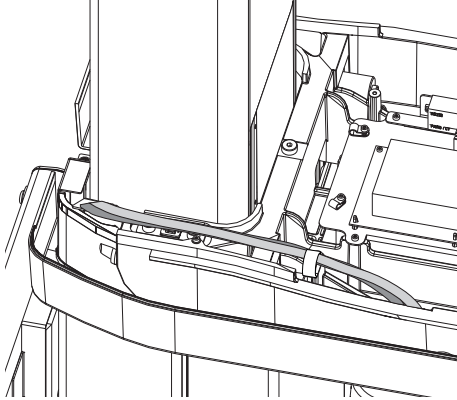

- › Guide the cables A01-CN1702 and A01-CN1706 through the clamps.

- › Secure the clamp with a screw.

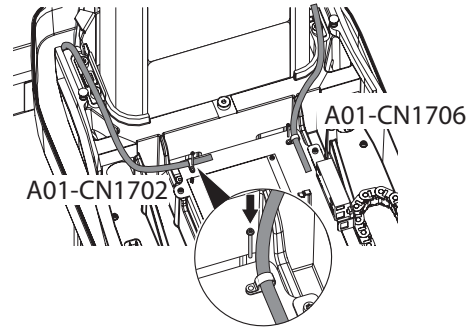

- › Connect the wiring connections from the column slide to the cables and sockets on the cross-member.

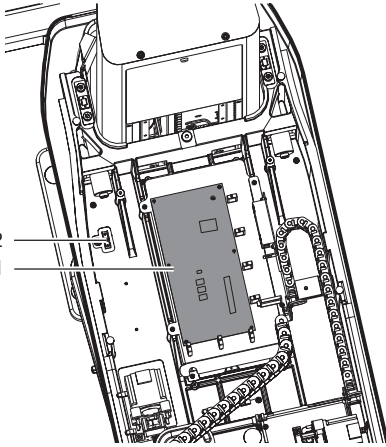

- 1 PCB A01
- 2 Protective ground connection

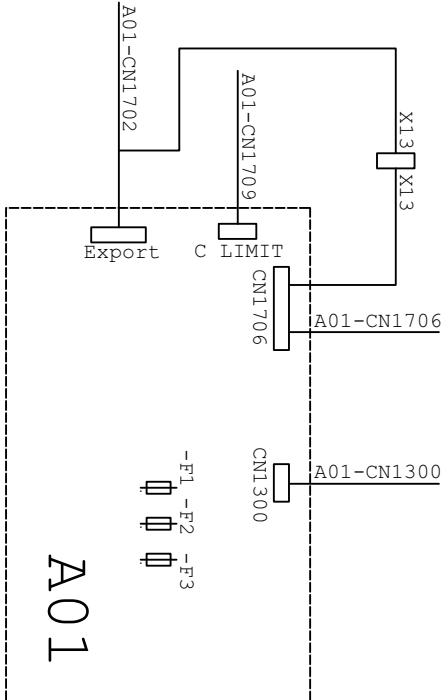

- › Attach the ferrite core of cable *A01-CN1706* close to *PCBA01*.
- › Using cable ties, tie together all cables that have been routed from the cross-member to the column slide and secure them. This will prevent any cables from being crushed during installation of the covers.

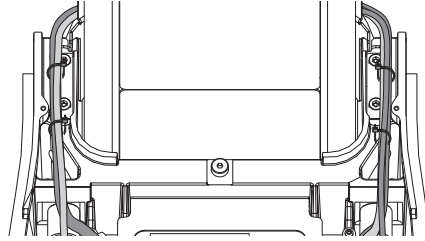

### Removing the transport locks

-  The screws may be difficult to remove as they are fitted with screw locks.

-  Do not dispose of the screws from the transport locks.

- › Remove the screws from the X-slide and Y-slide.

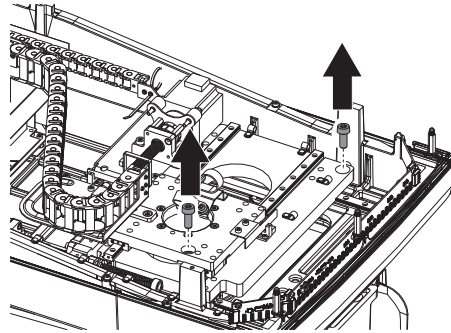



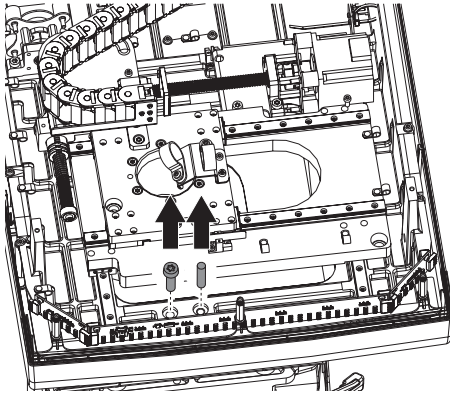

- › Remove the screw and threaded pin from the cross-member securing the rotating unit.

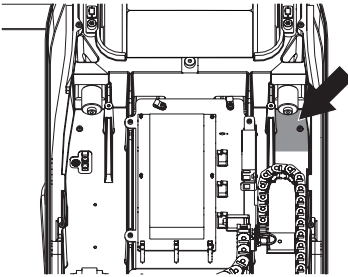

- › Remove the red adhesive tape.
- › Place the screws for the transport protection in the designated positions in the cross-member and secure them with adhesive tape if required.



### Installing the housing parts

-  Throughout the entire installation process, the rotating unit can be **SLOWLY** rotated to make the screws for attaching the covers easily accessible.
-  Tighten all the screws on the covers to 1 Nm (0.74 ft\*lb).

- › Loosen the four screws of the mounted covers, but do not remove them completely.

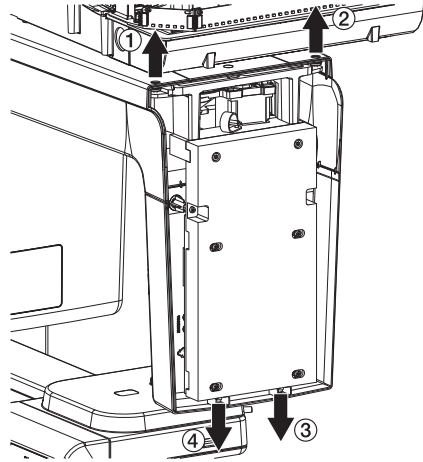

- › Position the cover on the rotating unit and slide it to the rear.

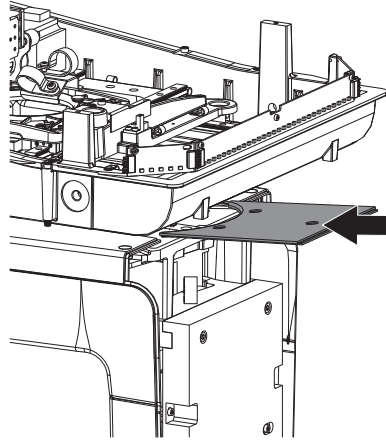

› Secure the cover with a screw and washer.

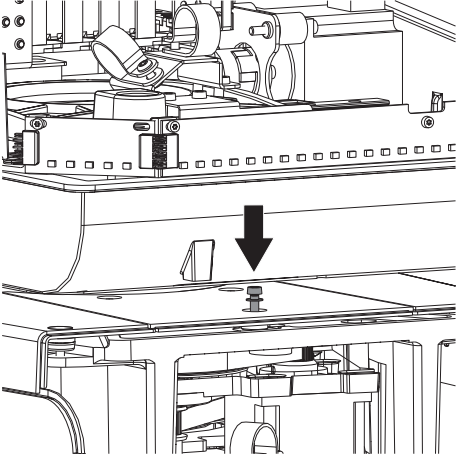

› Attach the sensor cover and retightened the loosened screws.  
In the process, make sure that the four mountings on the sensor cover are plugged in between the cast bracket and cover.

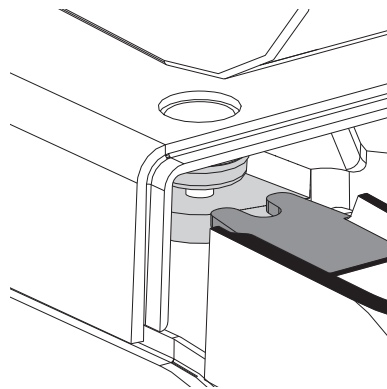
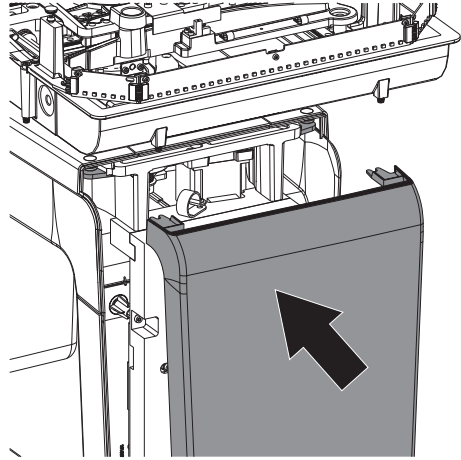

- › Mount the lower covers on the left and right of the cross-member.

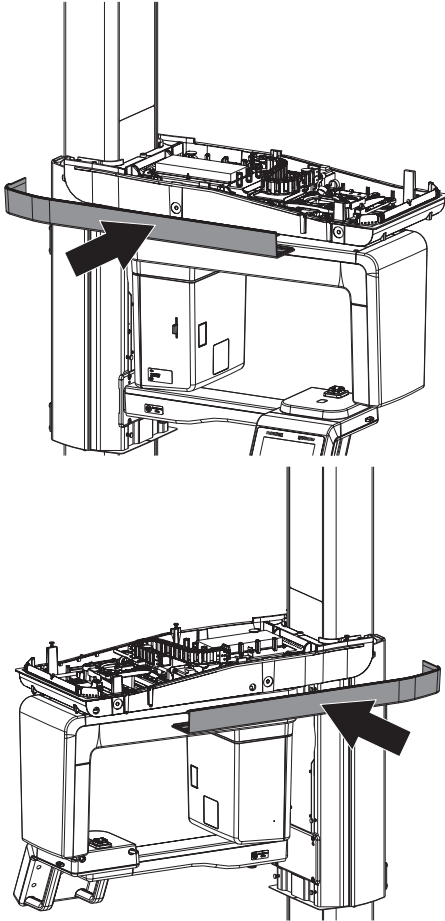

- › Check to make sure that the covers are seated correctly.

The Y-cover (white plastic panel) must lie between the housing and the cast part of the cross-member. The notch in the Y-cover must face forwards and be located in the designated mounting of the housing.

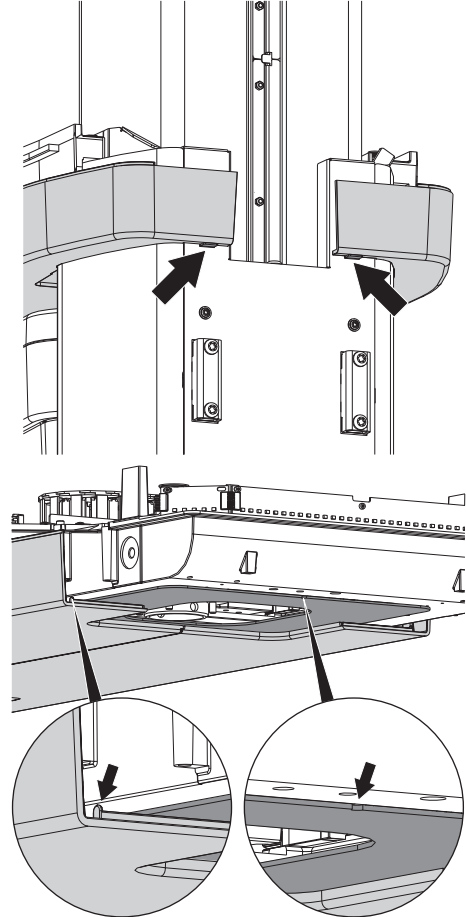

*Fig. 2: Illustration with the rotating unit not shown.*

› Tighten the lower covers on the left and right.

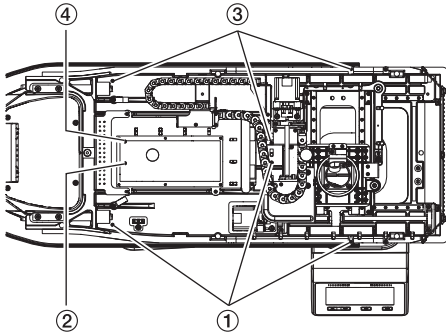

- 1 Left-hand cover: three screws with washers screwed in from above
- 2 Left-hand cover: one screw with washer screwed in from below
- 3 Right-hand cover: three screws with washers screwed in from above
- 4 Right-hand cover: one screw with washer screwed in from below

› Mount the lower cover to the front of the cross-member.

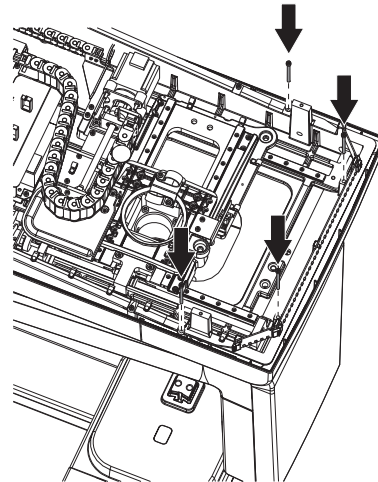
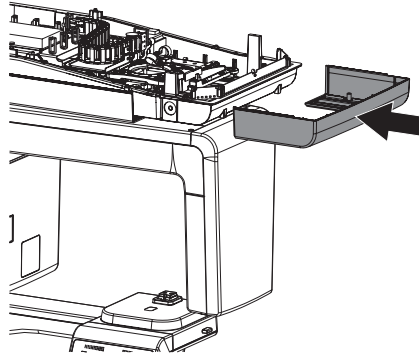

- › Mount the upper cover of the cross-member.  
For the installation use screws with washers.

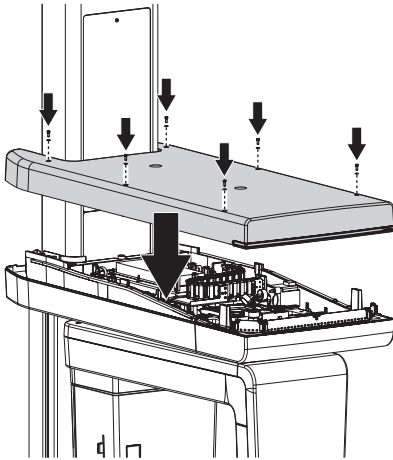

- › Mount the upper column cover.  
For the installation use screws with washers.

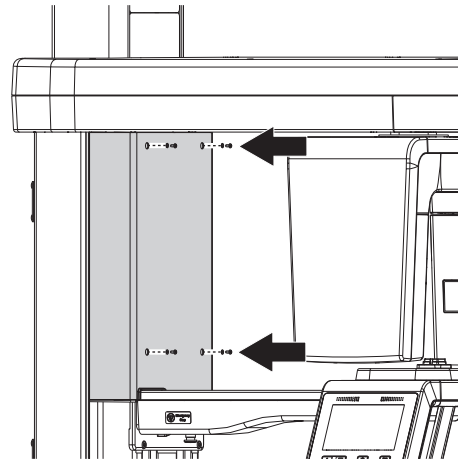
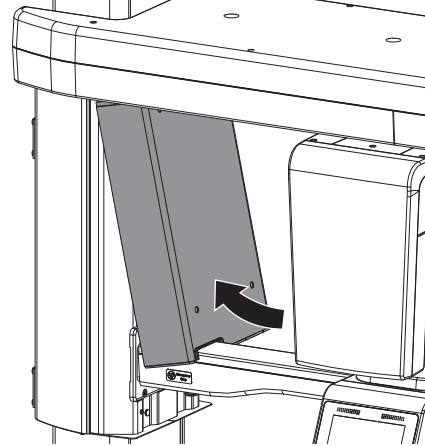

- › Mount the lower column cover.  
For the installation use screws with washers.

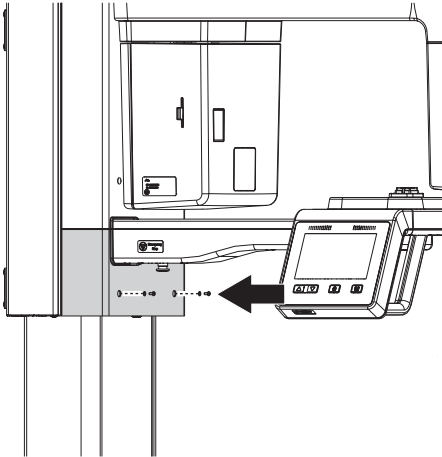
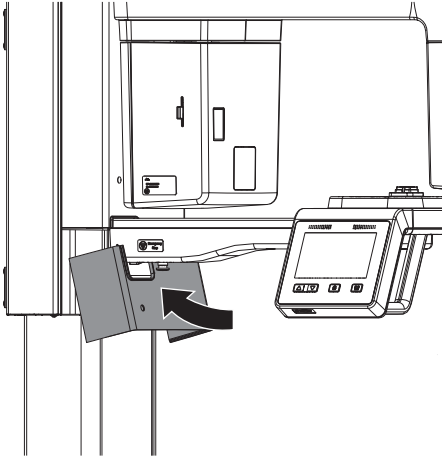

- › Do not yet fit the silicone covers for the screw holes in case any parts of the housing need to be taken off again.

### Installing the Ceph head

- › Install the Ceph head.  
Thread the cable from the Ceph head through the Ceph arm. Then connect this to the cable from the column slide.

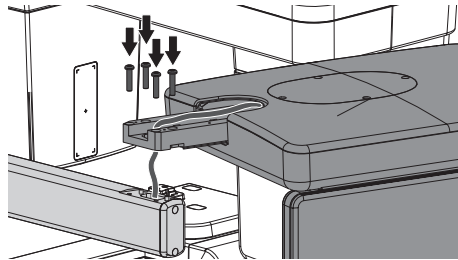

### Remove the transport locks

- › Take off the adhesive tape and remove the cover.

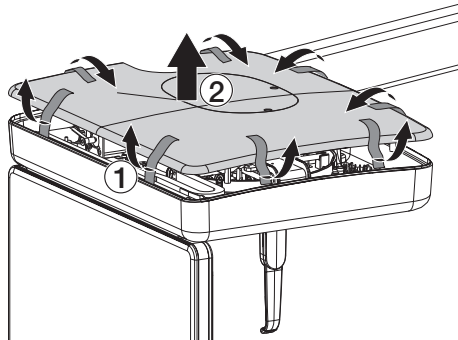

- › Remove the transport locks.

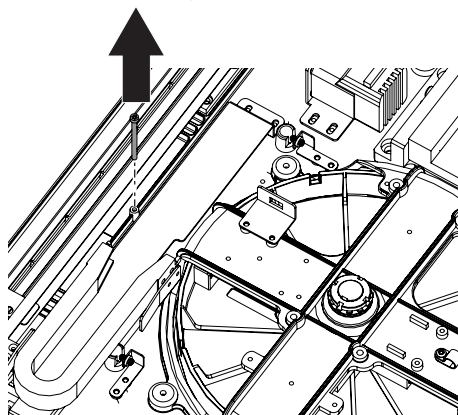

- › Use four screws, four washers and four protective caps to attach the covers to the Ceph head.

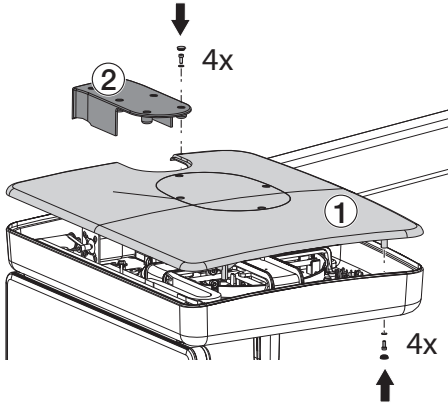

- › Use three screws to attach the cover to the connections PCB.

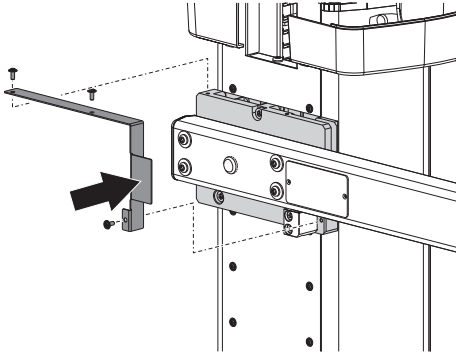

### Installing the ear rod holder

-  The ear rod holder on the left includes a metal pin.

- › Use two screws to attach the left and right ear rod holders to the Ceph head.

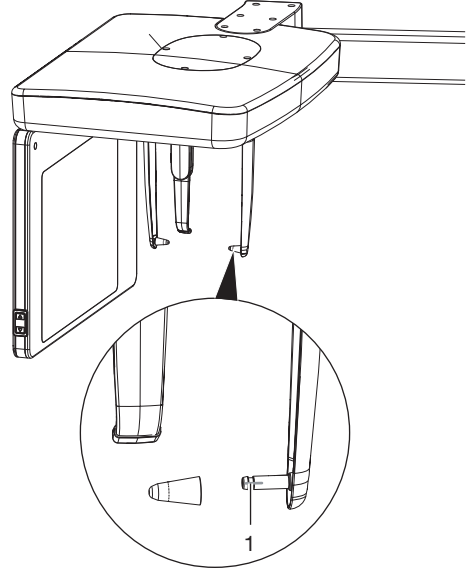

1 Metal pin

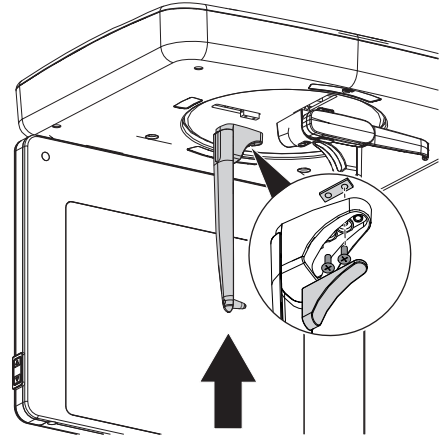

- › Attach the screw cover.

## Removing the protective films

- › Remove the protective films from the beam localizers.

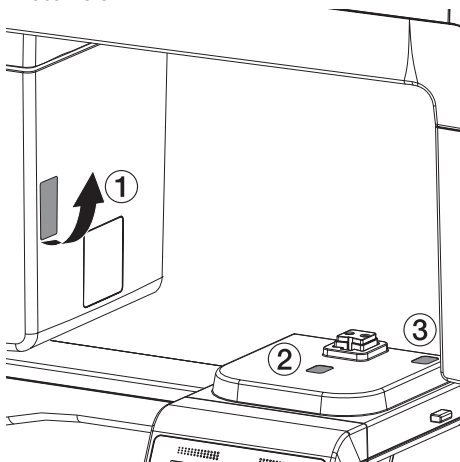

## 7.4 Preparation of the reconstruction computer

The unit supports the following imaging programs:

- VisionX from Version 2.4 from Air Techniques can be downloaded from [www.airtechniques.com](http://www.airtechniques.com)

### Computer settings

#### Windows configuration:

- › Set all power saving functions in the energy options or the Power Plan to **Maximum Performance**.
- › Add the folder *VistaVoxPlugin* under *C:\ProgramData\Duerr\VistaSoft\WorkstationService* (default directory, the actual folder may differ from this in some cases) as an exemption to the antivirus program (e.g. Windows Defender).
- › *Adjust the settings for User Account Control to Never notify.*  
To do this, pull the slider all the way to the bottom.
- › Windows 10 only:  
Under *HKEY\_LOCAL-MACHINE\SOFTWARE\Microsoft\Windows\currentVersion\Policies\System* set the registry entry *EnableLUA = 0*.

#### BIOS configuration:

- › Launch the reconstruction computer in BIOS.

- › Make the following setting: *Runtime Power Management: Disable*.
- › Make the following setting: *Idle Power Saving: Normal*.
- › Make the following setting: *C1E (BIOS Update): Disable*.
- › Disable all energy saving settings of the PCIe slots.
- › For all operating systems:  
Restart the reconstruction computer.

### Installing the driver(s)

If the additional component of the unit was not installed along with the installation of the imaging software, it can be installed later on.

- › Insert the installation data carrier or run the installation file.  
The Start menu opens.
- › If the Start menu does not open automatically, run the file *Start.exe*.
- › Select the installation language you require.
- › Accept the License Agreement.
- › Select the required components.
- › Select the *ProVecta 3D Prime* unit.
- › Follow the further instructions given by the installation wizard.

### Installing the frame grabber card and USB dongle

- › The enclosed frame grabber card is installed in the reconstruction computer (PCI Express slot Gen2 x4).
- › Plug the USB dongle into a free USB port.

## 7.5 Connecting the unit

### Overview of connection



#### NOTICE

#### Equipment damage due to excessive electric voltage

- › The voltage connected to the door contact switches and exposure switches must not exceed 24 V.



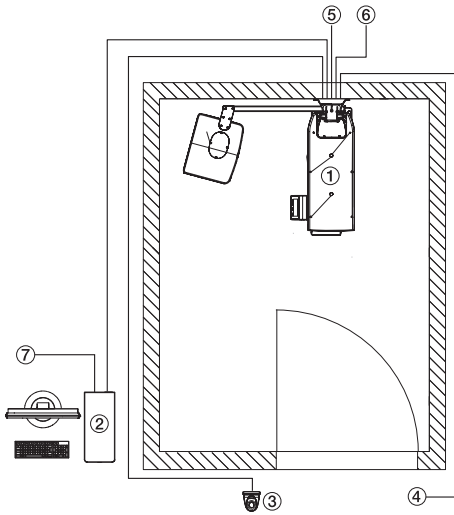

- 1 ProVecta 3D Prime Ceph
- 2 Reconstruction computer with frame grabber card
- 3 Exposure switch
- 4 Door contact
- 5 Mains AC power connection
- 6 Equipotential bonding (optional)
- 7 Network connection to the practice network

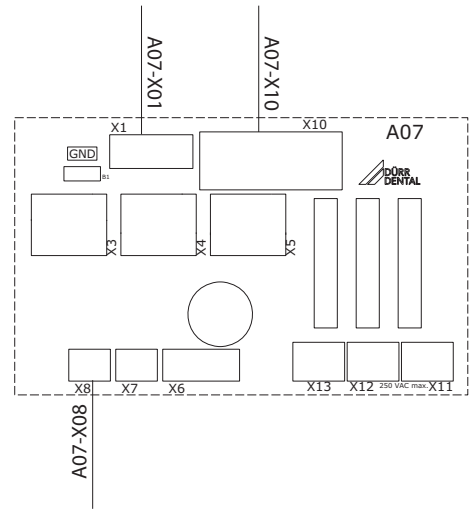

- X1 A01 (internal)
- X2 GND (internal)
- X3 Exposure switch / door switch / manual switch for height adjustment
- X4 Exposure switch / door switch / manual switch for height adjustment
- X5 Exposure switch / door switch / manual switch for height adjustment
- X6 Pin 1: GND  
Pin 2: +24 VDC (max. 5 mA)  
Pin 3: yellow status LED (active = GND). Series resistor 10 kΩ.  
Pin 4: green status LED (active = GND). Series resistor 10 kΩ.
- X7 Exposure switch (normally open contact)
- X8 Door switch (X-ray release when the contacts are closed)
- X10 Diagnostics (service)
- X11 - X13 Potential-free contact (normally open contact): unit switched on – max. 250 VAC; unit ready to acquire an image – max. 1.5 A; X-ray radiation active – at least 100 mW

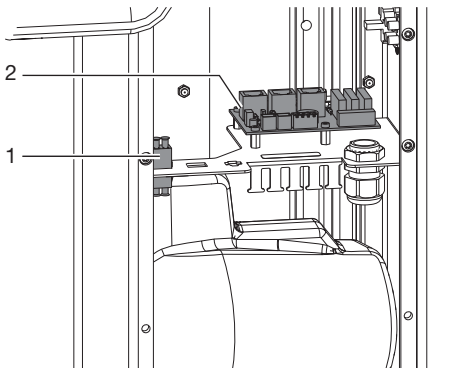

- 1 X01 Optic Pano: Connection to the reconstruction computer
- 2 PCB A07: Connection to the exposure switch, door contact switch, manual switch for height adjustment

All connected cables should be routed through the cable bushing at the foot of the column.

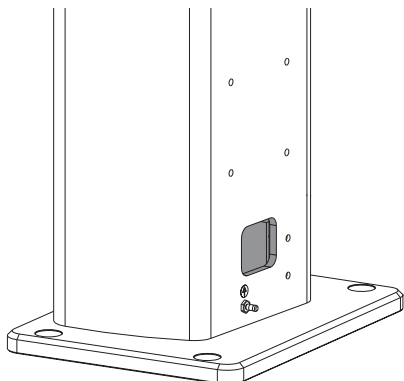

### Removing the housing cover

In order to be able to connect the unit, the front cover on the column needs to be removed.

- › Remove the screw.

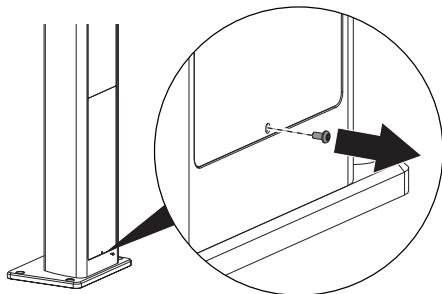

- › Remove the cover.

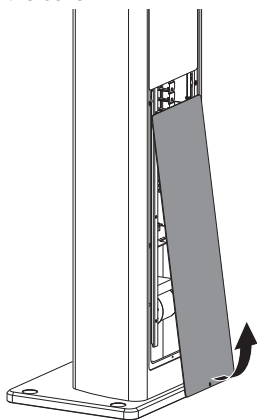

### Installing the exposure switch

- › Route the cable of the exposure switch through the cable bushing to the front into the column.
- › Connect the cable to the PCB A07. Slot X4

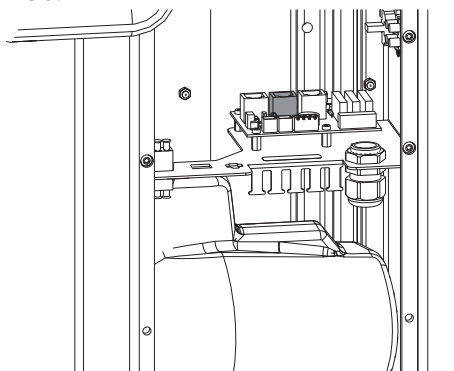

### Installing the door contact switch (optional)

A door contact switch can be connected to the unit via an RJ45 connection or via a 2-pole terminal connection.

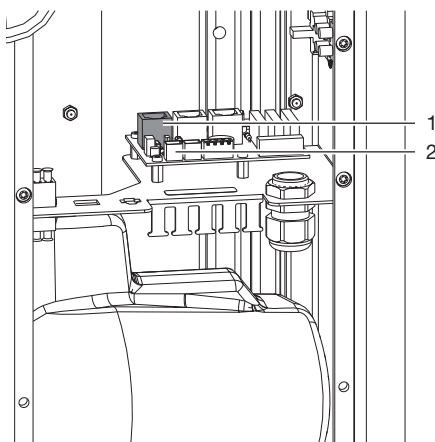

- 1 Slot X3: RJ45 connection
- 2 Slot X8: 2-pole connection, door contact

- › Remove the cable bridge from slot X8.

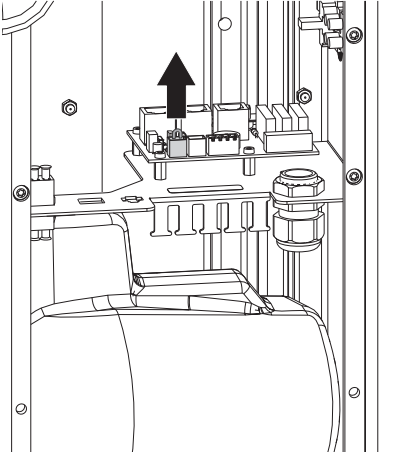

- › Route the cable of the door contact switch through the cable bushing to the front into the column.
- › When using slot X3 (RJ45), connect the signal from the door contact switch to Pin1 and Pin4.

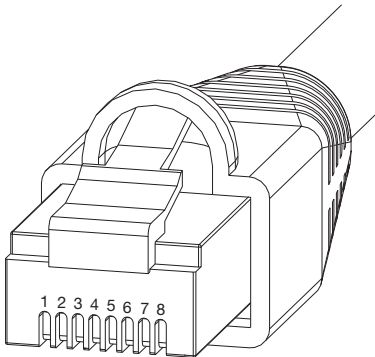



Fig. 3: Front view of RJ45 connector

- › Connect the cable to the PCB A07. Slot X3 or X8.
- › When using the slot X8 (2-pole connection), connect the cables to the terminal contact.

#### Connection of the equipotential bonding (optional)

If equipotential bonding is required in order to comply with local regulations and requirements for connections, this connection can be made via the connection on the rear of the unit. This connection is not required to meet the electrical

safety requirements in accordance with EN60601-1.

- › Connect the equipotential bonding cable (not included in the scope of delivery) to the connection on the unit. The connection complies with DIN 42801. The connection for the equipotential bonding is marked with the symbol .

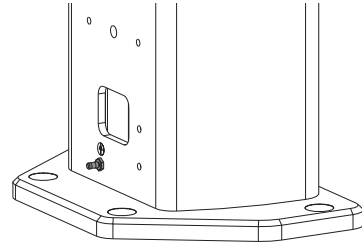

#### Connecting the device to a computer

*Connection with frame grabber card (order number A7799)*



Fiber optic cables are sensitive to dirt and dust. For this reason, do not remove the protective caps from the cable ends and plug sockets until just before you connect the cable. If the end of the cable gets dirty during connection then it will need to be cleaned. We recommend using a specialty cleaner for fiber optic cables (LC plug connections). Refer to the manufacturer's information when doing this.

Fiber optic cables are also sensitive to kinking. For this reason, do not to bend the cable at a sharp angle, but route it around corners with a radius of  $\geq 80$  mm.

- › Route the enclosed fiber optic cable or a longer fiber optic cable from the accessories (see "3.4 Optional items") through the cable bushing to the front into the column.

- › Remove the protective cap from the connector of the fiber optic cable and from the plug socket on the PCB and plug the fiber optic cable into the PCB.

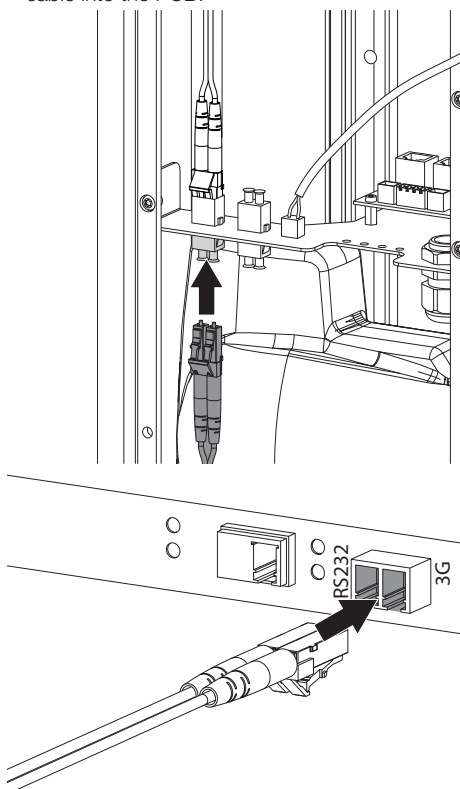

### Establishing the electrical connections

Requirements:

- The connection to the mains supply must be a fixed connection that can only be released using a tool. Plug-in connections (power outlet/plug) are not permissible.
- An all-pole disconnection unit (all-pole switch) is installed in the electrical connection to the mains power supply. This satisfies the creepage distances and air gaps specified in IEC 61058-1 for a mains voltage peak of 4 kV.
- The disconnection unit (switch) is easily and safely accessible.
- Mains fuse (16 A) present in the mains supply (protective circuit breaker characteristic B in accordance with IEC EN60898)
- Internal resistance of the mains supply <math>< 0.5 \Omega</math>

### Electrical safety when making connections

- › Make sure that none of the electrical cables leading to the unit are under any mechanical tension.
- › Before start-up, check the mains voltage against the voltage indicated on the type plate (see also "4.3 Model identification plate").
- › Make sure that the electrical connections to the mains power supply are established in accordance with current valid national and local regulations and standards governing the installation of low voltage units in medical facilities.
- › Note the current consumption of the devices that are to be connected.

### Combining devices safely

Take care when connecting units together or to parts of other systems as there is always an element of risk (e.g. due to leakage currents).

- › Only connect units when there can be no question of danger to operator or to patient.
- › Only connect units when it is safe to do so and when there is no risk of damage or harm to the surroundings.
- › If it is not completely clear from the data sheet of the unit that such connections can be safely made or if you are in any doubt, always get a suitably qualified person (e.g. the relevant manufacturer) to verify that the setup is safe.
- › When connecting the unit to other devices, e. g. a PC system, comply with the requirements set out in section 16 of IEC 60601-1 (EN 60601-1).
- › When setting up the PC system in the vicinity of the patient:  
Only connect components (e.g. computer, monitor, printer) that comply with the standard IEC 60601-1 (EN 60601-1).
- › When setting up the PC system outside of the vicinity of the patient:  
Connect components (e.g. computer, monitor, printer) that comply at least with the IEC 60950-1 (EN 60950-1) standard.

*Layout as 2/PE AC 200–240 V (US)*

- › Connect the wires of the mains connection cable to the mains.

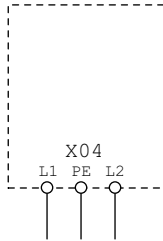
**Securing the cables**

- › Secure the cables of the PCB A07 with cable ties to the tabs on the sheet metal part.

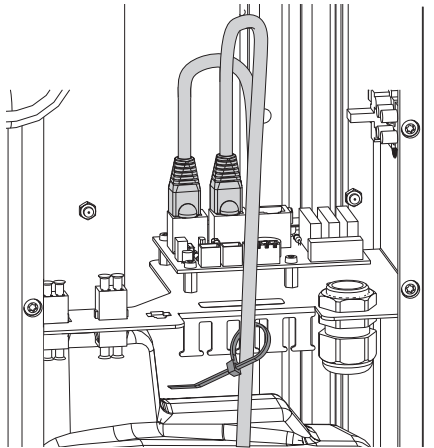

## 8 Commissioning and first start-up

**NOTICE****Short circuit due to the build-up of condensation**

- › Do not switch on the unit until it has warmed up to room temperature and is dry.

The required tests (e.g. acceptance test) must be done in accordance with local rules and regulations.

- › Find out which tests are required.
- › Carry out testing in accordance with local rules and regulations.

### 8.1 Switch the device on

**CAUTION****Danger of injury by moving rotating unit arm**

After the unit is switched on and the parameters are confirmed on the touch screen, the C-shaped angle connector piece is positioned. Persons can be injured during this.

- › Nobody may be present in the area of the rotating unit arm while the unit is being switched on.

- › Use the main power switch to switch the unit on.

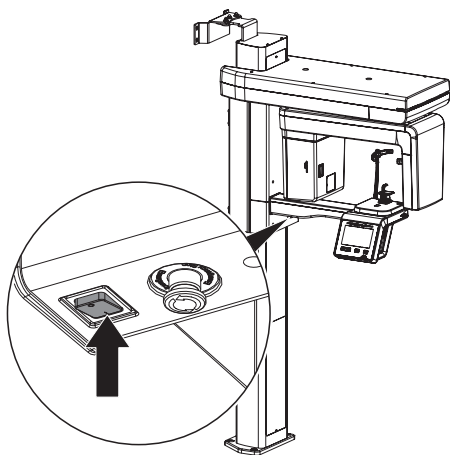

The main power switch lights up green after it is switched on. The status LED lights up blue.

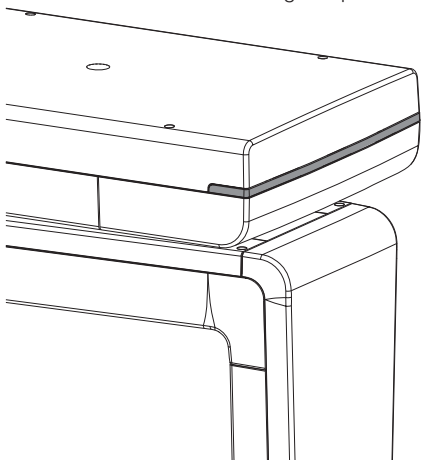

### Manual functional test

The manual functional test needs to be performed in order to ensure that no damage occurred during transport and installation/assembly.

-  Driving the unit up and down may trigger the overheating protection of the lift motor. Allow the unit to cool down in between.

- › Move the unit to the maximum height level of the unit.  
Are there any suspicious noises?

- › Move the unit to the minimum height level of the unit.  
Are there any suspicious noises?  
Is there a sufficient distance between the top cover of the housing and the ceiling?

### 8.2 Electrical safety checks

- › Carry out the electrical safety check according to national law (e. g. in accordance with IEC 62353).
- › Document the results.

### 8.3 Limiting the height adjustment

The height of the unit can be variably adjusted to match the height of the patient. The maximum height can be limited.

To ensure that the unit can be opened for servicing, we recommend keeping a minimum distance of 30 cm between the fully extended unit and the ceiling.

- › Move the unit to the lower height level of the unit.

 Check for correct alignment when fastening the adjustment cam. The beveled side must face downwards.

- › Remove the adjustment cam and screw it back on in the required position of the unit.

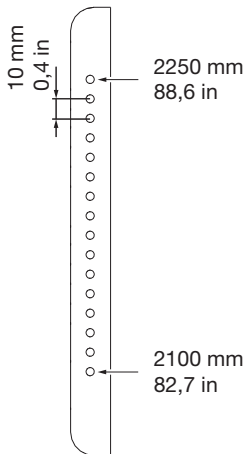
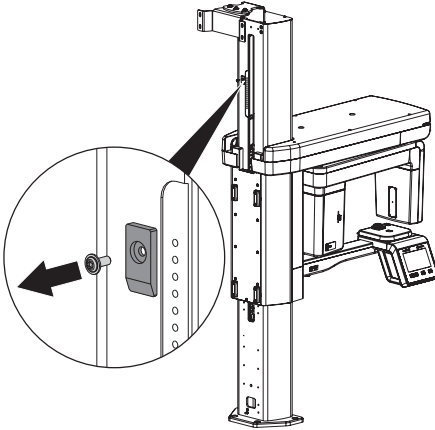

- › Move the unit to the maximum height level of the unit.  
Check that there is enough space between the upper part of the housing and the ceiling.

## 8.4 Checking the installation

 The settings are described using the example of the VisionX imaging software. VisionX can be downloaded from [www.airtechniques.com](http://www.airtechniques.com).

For further information regarding the use of the imaging software, refer to the relevant manual.

### Configuring the unit

The configuration is done in the settings of the imaging software.

- › Start the imaging software.
- › Click .
- › Click *Devices*.
- › Check to make sure that the checkmark is placed in the column *Connected*.  
This shows that the unit is connected to the imaging software and that it has been detected.

## 8.5 Calibrating the unit

The unit must be calibrated in order to obtain homogeneous, defect-free and reproducible X-ray images.

Here, the radiation field on the sensor is adjusted by aligning the child and adult collimators.

- ✓ VisionX 2.4 or higher installed
- ✓ ProVecta plugin installed
- ✓ USB stick with device-specific calibration data is plugged in on the reconstruction computer

 The path information is for the default installation.

 The USB stick contains device-specific calibration data. We recommend storing the stick with the documents of the device (e. g. X-ray facility book, operating instructions).

- › Plug the USB stick with device-specific calibration data into an unoccupied USB port.

- › Start the service tool on the reconstruction computer.  
To do this, run the file *ServiceTool initial installation* under `C:\ProgramData\AIR TECHNICAL\QUES\VisionX\WorkstationService\VistaVox-Plugin\VistaVoxServiceTool`.  
The service tool starts up with the workflow required for the configuration. All other workflows are not available.  
If the service tool is to be started up with all workflows, open the file *Start ServiceTool* in the same directory.
- › The service tool guides you through the setup and calibration of the unit.

## 8.6 Carrying out a functional test

In countries, in which the acceptance and consistency checks are a legal requirement, the functional test can be omitted.  
The functional test must be performed to ensure correct operation of the unit after installation and during operation. We recommend performing the functional test right after the installation and then every 4 weeks. The functional test can also be performed if there are problems with the image quality as a way to narrow down the root cause. Tests such as operational check, electrical safety tests are regulated by the local and federal code.

- Find out which tests are to be made and the required intervals for your specific installation.
- Conduct tests in accordance with code.

### Required test equipment and software

Required test equipment:

- Test phantom set for pano
- Ceph X-ray test phantom holder
- Test phantom set for CBCT

Software required:

- Imaging software

### Creating patient

A dummy patient needs to be created so that the images can be acquired for the functional test.

- › Start the imaging software.
- › Create a patient named *Functional test*.
- › Log in the created patient.

### Performing a pano functional test

#### *Positioning the test phantom*

- › Remove the mounting for bite block, chin supports etc.
- › Insert the holder for the pano test phantom.

- › Insert the pano test phantom in the holder.

#### *Taking the X-ray image*

- › Take a test image.  
Parameters: Pano Standard, HD, patient shape "Normal", jaw arch "Normal", 60 kV, 4 mA
- › Evaluate the test image.  
At least 2.5 LP/mm and two contrast bores must be visible.  
The image must be uniform and free of artifacts.



Since this image is a processed X-ray image, it may appear noisy. This is normal and has no impact on quality.

### Performing a functional test of the Ceph X-raying function

#### *Positioning the test phantom*

- › Rotate the Ceph positioning aids to the *PA* position.
- › Grasp the holder for the ear rods at the top and push it outwards (opened maximally).
- › Swivel the nose support to the side.
- › Insert the Ceph test phantom holder.
- › Insert the pano test phantom in the holder. The side with aluminum must face the sensor.

#### *Taking the X-ray image*

- › Take a test image.  
Parameters: Cephalometric projections PA, HD, patient shape "Normal", 85 kV, 10 mA
- › Evaluate the test image.  
On the test phantom the numbers must be legible and four contrast bores must be visible.  
The image must be uniform and free of artifacts.



Since this image is a processed X-ray image, it may appear noisy. This is normal and has no impact on quality.

### Performing a CBCT functional test

#### *Positioning the test phantom*

- › Remove the mounting for bite block, chin supports etc.
- › Insert the holder for the CBCT test phantom.
- › Level the holder with the aid of the integrated spirit level and adjusting screws.
- › Place the complete test phantom (which is made up of several parts) on the holder for the test phantom.



### *Taking the X-ray image*

- › Take a test image.  
Parameters: CBCT, image volume "Normal",  
HD, patient shape "Normal", 94 kV, 8 mA
- › Evaluate the test image.  
The image must be uniform and free of arti-  
facts. The visible object must be square on the  
inside and outside.

# ? Troubleshooting



**CAUTION**

Any oil leaking from the X-ray tube in the event of a fault is harmful.

- › Wipe up any oil immediately.
- › Do not swallow the oil.
- › Stop using the unit and inform a service technician.

## 9 Tips for operators and service technicians



Any repairs above and beyond routine maintenance may only be done by suitably qualified personnel or by one of our service technicians.

Error	Possible cause	Remedy
<b>Unit does not switch on</b>	EMERGENCY STOP SWITCH accidentally activated	› Releasing the EMERGENCY STOP SWITCH.
	No mains voltage	› Check the mains cable and electrical connection; replace if necessary. › Contact technician.
		› Check the mains fuse in the building.
	On/off switch is defective	› Contact technician.
<b>Unit not responding</b>	The unit has not yet completed the startup procedure	› After switching on, wait until the booting process has finished.
	Cables not correctly connected	› Check the cable connections.
	Plug-in contacts of the fiber optic cable are contaminated	› Clean plug-in contacts and sockets.
	Driver for PCI Express frame grabber card is not installed or incorrectly installed	› Reinstall the driver or the complete ProVecta plugin.
	COM port incorrectly configured	› Check the COM port in the service tool.

Error	Possible cause	Remedy
<b>Error messages during start of the acquisition of an X-ray image or during shut down of the PC</b>	Energy-saving options incorrectly configured	<ul style="list-style-type: none"> <li>› Deactivate the energy-saving options in Windows and the BIOS completely.</li> </ul>
	Supply voltage for graphic card inadequate or incorrectly connected	<ul style="list-style-type: none"> <li>› Check the plug connections.</li> <li>› Compare requirements of the graphic card with the power supply of the PC, use larger power supply if necessary.</li> </ul>
	PC and/or graphic card fail to comply with the specified system requirements	<ul style="list-style-type: none"> <li>› Set up the system in accordance with the system requirements.</li> </ul>
	User account control (UAC) has not been correctly configured	<ul style="list-style-type: none"> <li>› Make the user account control settings according to the information in the installation instructions.</li> </ul>
	USB dongle not detected	<ul style="list-style-type: none"> <li>› Check whether the USB dongle (included in scope of delivery) is plugged into the reconstruction computer, or check that the USB dongle is correctly plugged in.</li> </ul>
	Virus scanner prevents the acquisition of an X-ray image	<ul style="list-style-type: none"> <li>› Add the installation paths of the imaging software as exceptions in the virus scanner.</li> </ul>
	Firmware of the device does not match the software version	<ul style="list-style-type: none"> <li>› Check software versions and update if necessary.</li> </ul>
	The device calibration has not been imported or incompletely imported	<ul style="list-style-type: none"> <li>› Carry out initial commissioning using the service tool again/initially.</li> </ul>
Door contact is not closed	<ul style="list-style-type: none"> <li>› Check door contact and plug-in connections of the door contact, close door properly.</li> </ul>	

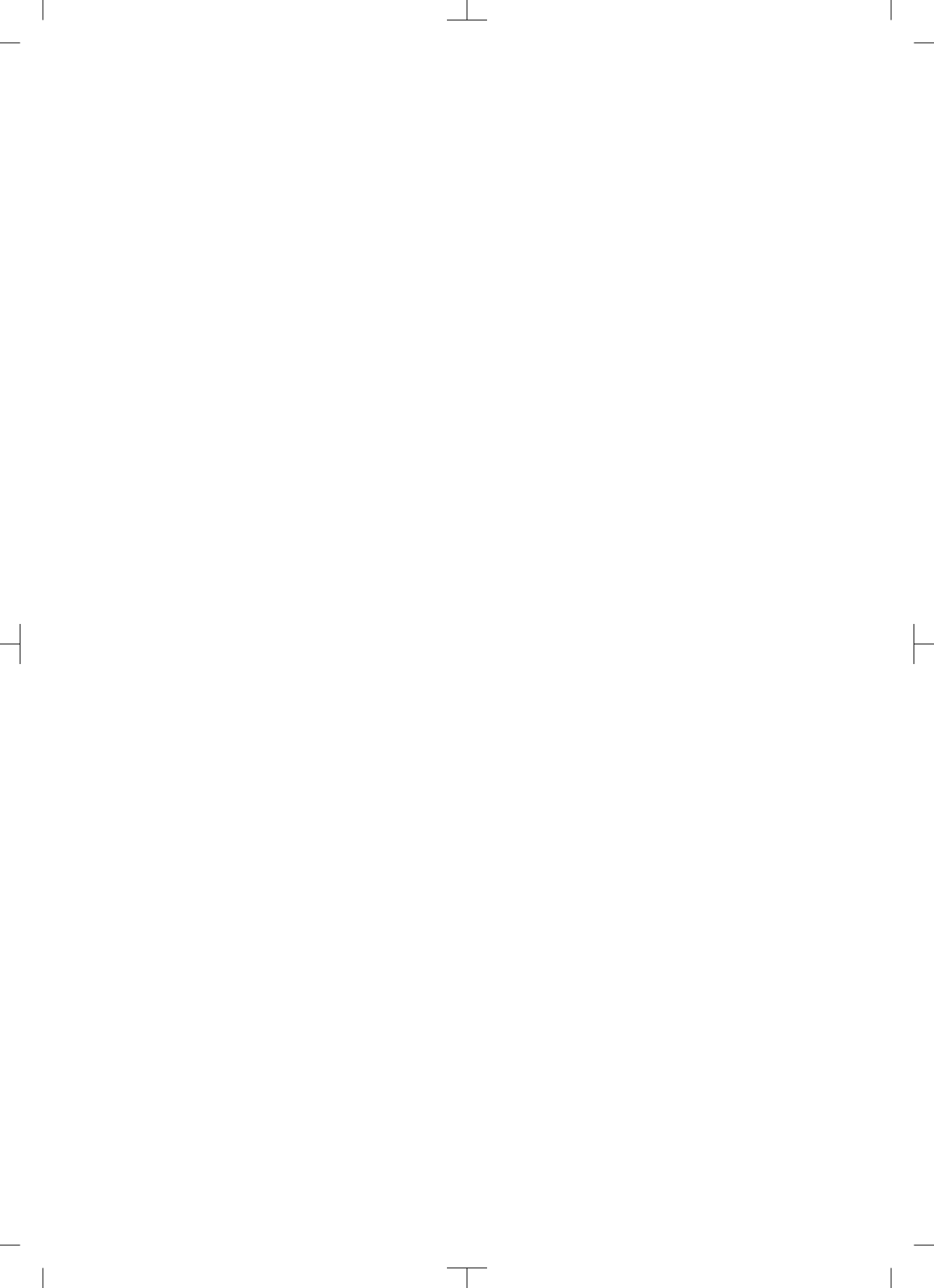

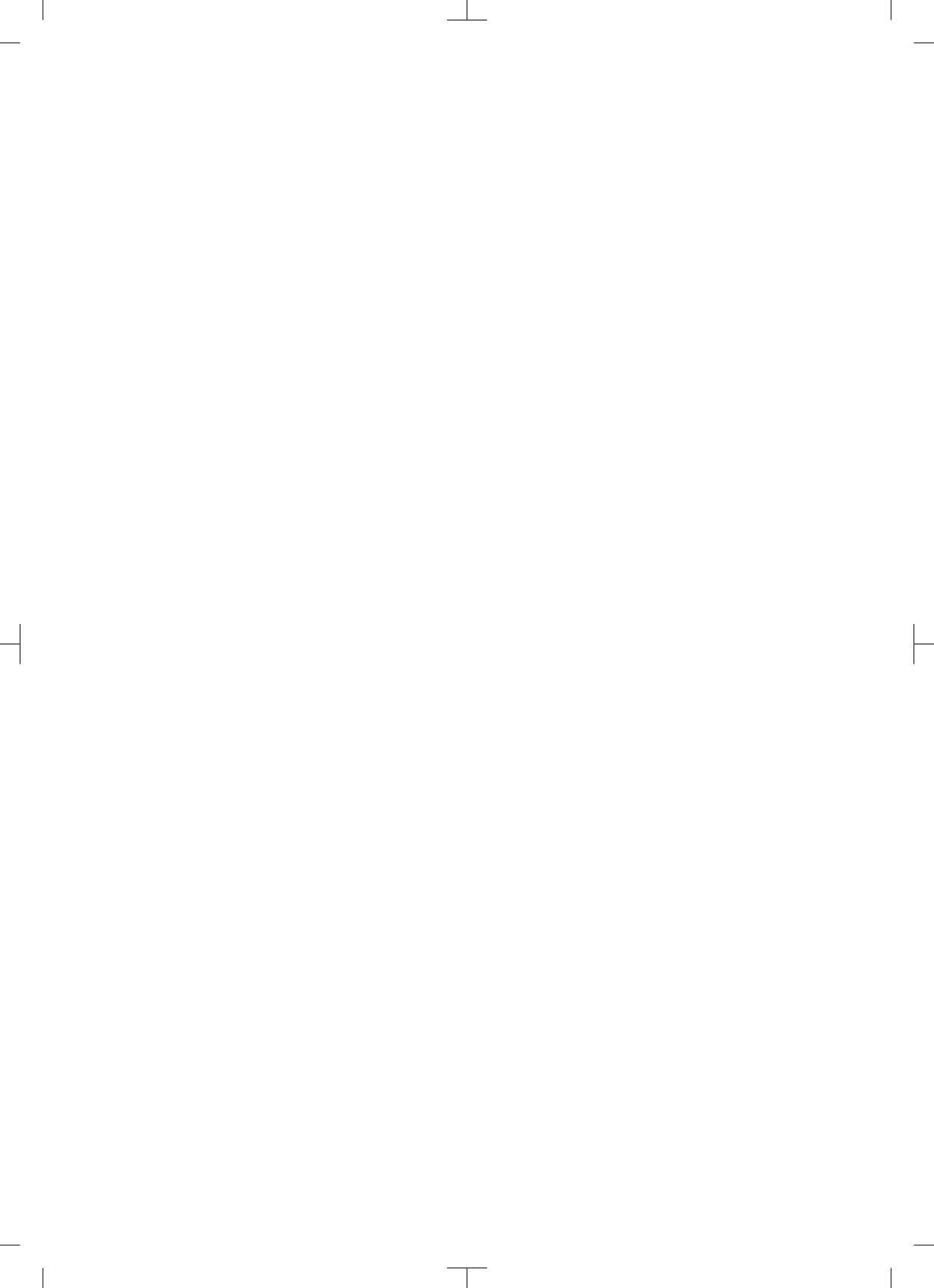

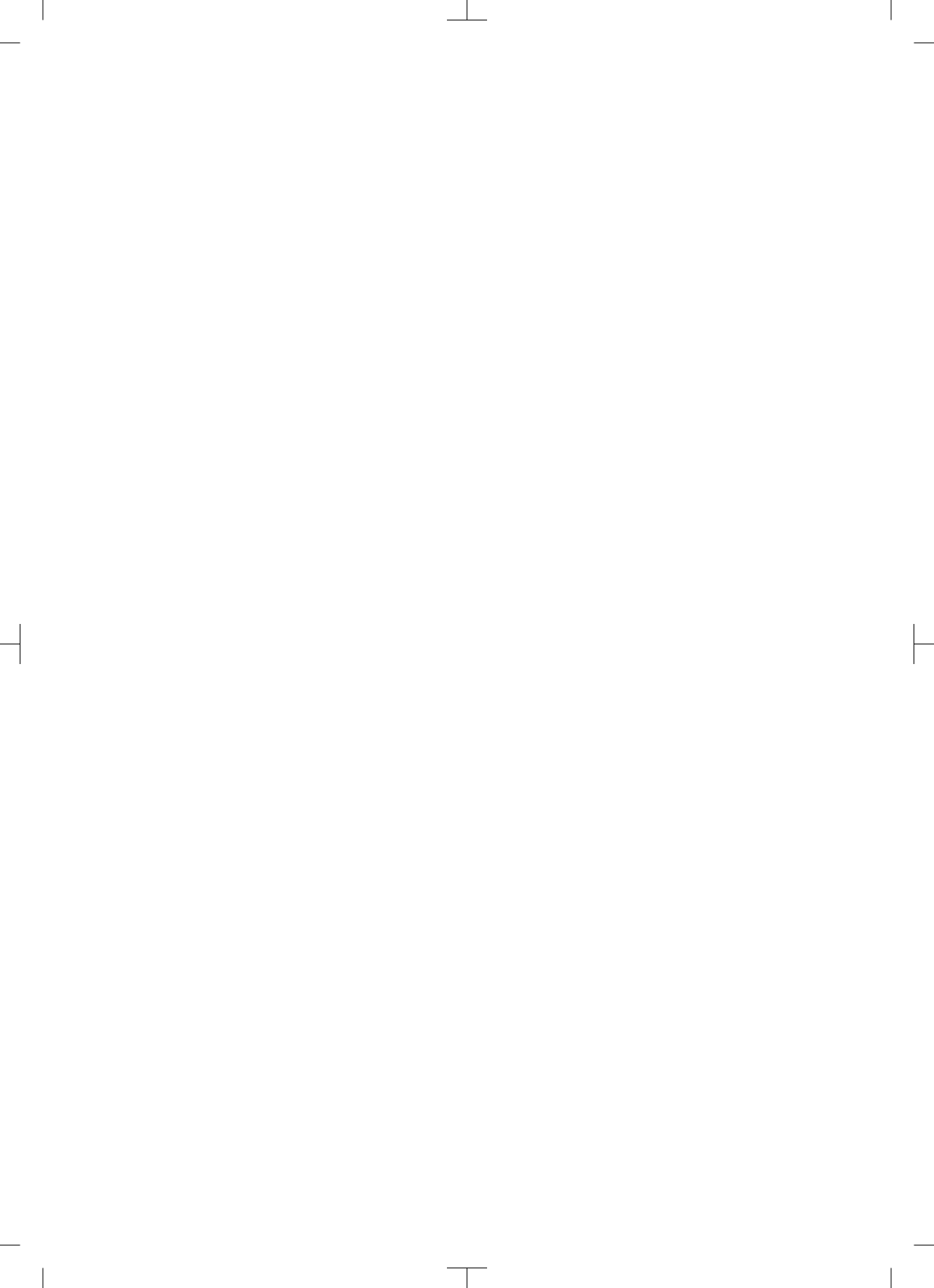

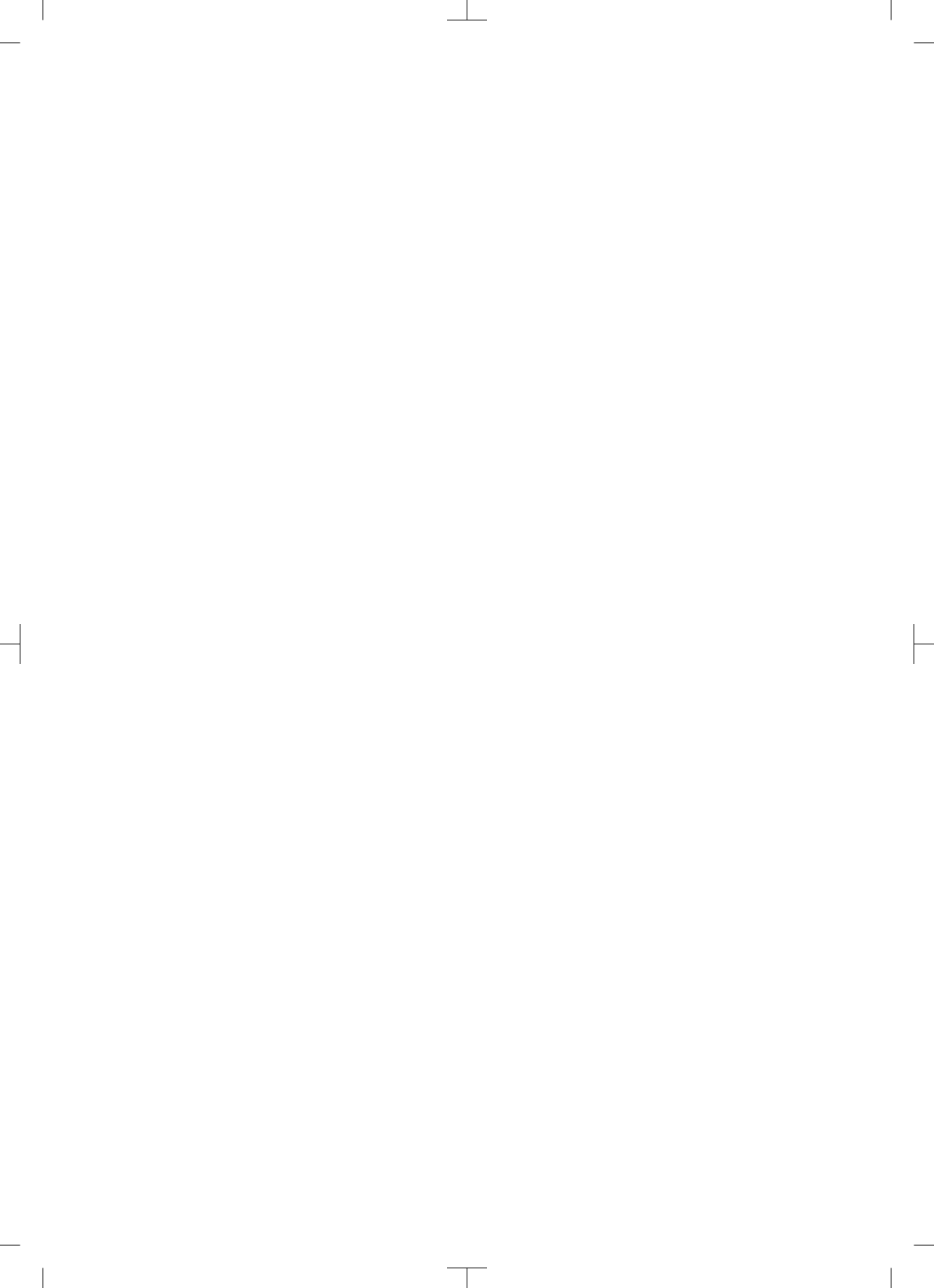



**Hersteller / Manufacturer:**

DÜRR DENTAL SE  
Höpfigheimer Str. 17  
74321 Bietigheim-Bissingen  
Germany  
[www.duerrdental.com](http://www.duerrdental.com)

**Manufactured for / Distributed by:**

Air Techniques, Inc.  
1295 Walt Whitman Road  
Melville, New York 11747-3062, USA  
Phone: 800-247-8324  
Fax: 888-247-8481  
[www.airtechniques.com](http://www.airtechniques.com)

