

ACADIA® PLUS AMALGAM SEPARATOR

Collection Container and Recycling Kit Part Number: APREC Replacement Instructions

Introduction

This document provides the instructions to replace the Collection Container of an **Acadia Plus** Amalgam Separator using Collection Container Recycling Kit, Part Number APREC. The use period for a Collection Container on either an existing Dry Vacuum System or Liquid Ring Pump System is 12 months or less depending on the capacity of the system. Included are procedures to replace and package the filled Collection Container for recycling. This replacement should be performed only by authorized Air Techniques Dealer service personnel.

Replacement Kit Components- Supplied

As shown by Figure 1, each kit contains a Container Locking Lid, A1355; Shipping Container, A1365; Collection Container, A1630; and Recycling Cap, A1642. A Prepaid Shipment Label is supplied with the kit. Canadian Recycling Literature is also included.

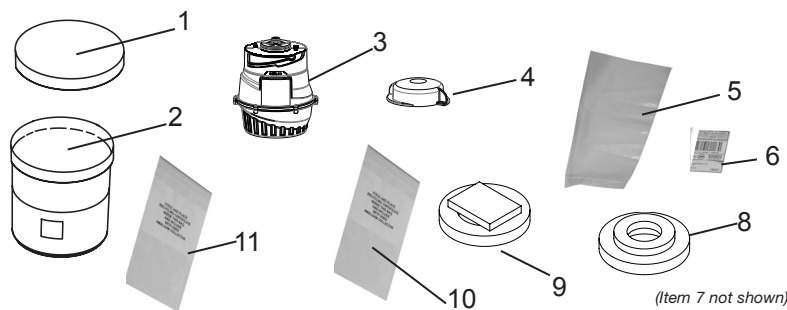

Kit Components Supplied

Item	Description	Part No.
1	Container Locking Lid	A1355
2	Shipping Container (bucket)	A1365
3	Collection Container	A1630
4	Recycling Cap	A1642
5	Ziploc Container Disposal bag	9929-139
6	Prepaid Shipment Label	A1425

Item	Description	Part No.
7	2 Adhesive Liners (not shown)	A1413
8	Top Shipping Ring	A1644-1
9	Bottom Shipping Ring	A1644-2
10	Canadian Recycling Literature	A1418
11	Replacement Instructions	A1647

Figure 1. Collection Container and Recycling Kit, Part Number APREC

Important: The Collection Container is not to remain in use for a period longer than 12 months (one year) from the date of installation.

Dental Waste Handling

Collection Containers collect waste materials from dental procedures. All maintenance personnel must be familiar with the procedures and practices for handling such dental waste and exercise every precaution to ensure personnel safety. Additionally, personnel must follow all local, state and/or federal laws and regulations for the proper disposal of dental waste containing mercury. Any operation, procedure or practice, which, if not strictly observed, may result in injury or long-term health hazards to personnel. Filled Collection Containers being sent for recycling should be handled, stored and disposed of according to regulations applying to dental waste containing mercury.

Proper Disposal of Amalgam Collector

After installation by an authorized Air Techniques Dealer, the Collection Container will trap mercury-containing materials. Mercury is a defined and regulated "hazardous substance" under many local, state, and/or federal regulations. Accordingly, at the end of the use period, arrangement must be made for proper disposal of the Collection Container and its contents in accordance with all local, state and/or federal laws and regulations.

Unpacking Replacement Container

Refer to Figure 2 and unpack the replacement Collection Container as follows.

1. Open both shipping cartons and remove the Shipping Container (bucket).
2. Remove the Cartridge from the Shipping Container.
3. Make sure that all components shown by Figure 1 were received.
4. Discard the Outer Shipping Carton and set aside the Replacement Container, Shipping Container, Interior Carton, and all packaging necessary to pack the used (filled) Collection Container for reshipment to recycling service provider.
5. Place the new replacement Container aside for later use in the Collection Container replacement procedure.

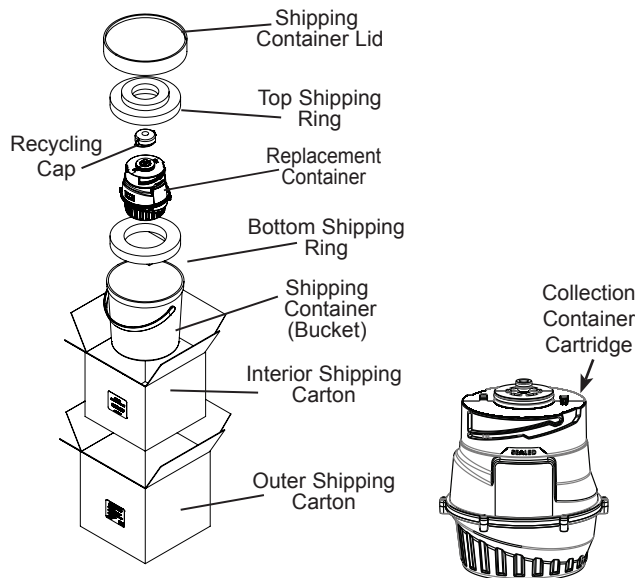

Figure 2. Unpacking Replacement Container

CAUTION: DO NOT use Chlorine Bleach or solutions of sodium Hypochlorite to clean or disinfect the vacuum system or disposable Collection Container. Sodium Hypochlorite (Bleach) will reduce effectiveness of the Container.

WARNING: Make sure to wear skin and eye protection when performing the following replacement procedures.

Collection Container Replacement Procedure

This replacement procedure provides instructions to replace the Container to return the **Acadia Plus** to service; and to package the filled Collection Container for recycling. The replacement procedures are accomplished with the vacuum system running. All hand piece and suction devices must also be turned off during the entire Container change out procedure to maintain constant vacuum system pressure.

Important: Keep the vacuum system running and maintain constant vacuum pressure by not working on patients or opening any hand piece or suction devices during the entire collection Container change out procedure

Container Replacement Procedure. Replacement of the Collection Container consists of removing the used Container from the **Acadia Plus** separator unit and installing in its place the replacement Container provided in the kit. Make sure to wear skin and eye protection when performing the following replacement procedures. Keep the Container bagged and upright to prevent spills. It is also recommended to wait until the liquid has drained down into the Collection Container to be removed before proceeding. Replace the Collection Container used on the **Acadia Plus** separator unit by performing the following Container removal and installation procedures.

Container Removal. With the vacuum system running, remove the used (filled) Collection Container from the **Acadia Plus** separator unit as follows:

1. Open the supplied Ziploc Disposal Bag and slip it up and over the Collection Container to be removed.
2. With the Container in the Ziploc bag, carefully remove the Container by turning it to the left and lowering away from the **Acadia Plus** separator unit.
3. Set the removed Container aside and immediately install the replacement Container in accordance with the procedure below.

Container Installation. Install the Collection Container onto the **Acadia Plus** separator unit by performing the following steps.

1. Remove the replacement Container from the protective bag and discard bag.
2. Lift the replacement Container into place and secure by turning to the right.
3. Make sure the replacement Container is properly installed before releasing.
4. Record the installation date on the label.
5. Ship the used Container to the recycling service provider by performing the Container Pack and Ship Procedure on the next page.

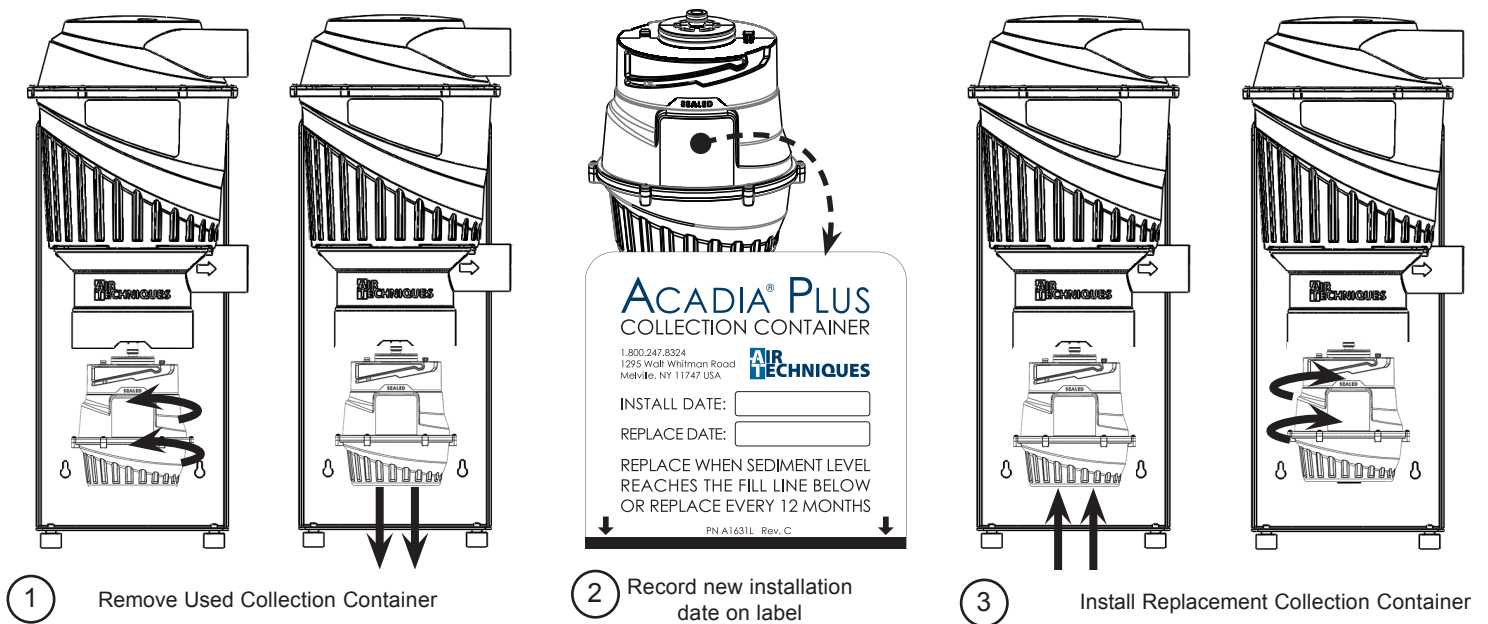

Figure 3. Collection Container Replacement

Important: Refer to the Acceptable - Non-Acceptable Materials List supplied with the kit for the acceptable materials allowed for shipment to the recycling vendor.

Container Pack and Ship Procedure .

Refer to Figure 4 and pack the Collection Container for shipment by performing the following steps.

1. Push the Recycling Cap onto Collection Container and twist clockwise to secure. Make sure that the two ledges on the edge of the cap are tucked under the tabs on top of the container.
2. Close the Ziploc Disposal Bag containing the Container removed from the **Acadia Plus** separator unit and place in the shipping container (bucket) in between the top and bottom shipping rings.
3. Replace lid on the white bucket and twist securely closed.
4. After securing the lid, place one of the supplied adhesive liners from the lid to the side of the shipping container.
5. Place the closed shipping container into the interior carton and seal with the remaining supplied adhesive liner.
6. Fill out the shipping return label. This information is mandatory. Upon request, a Certificate of Recycling will be returned using the information on the label.

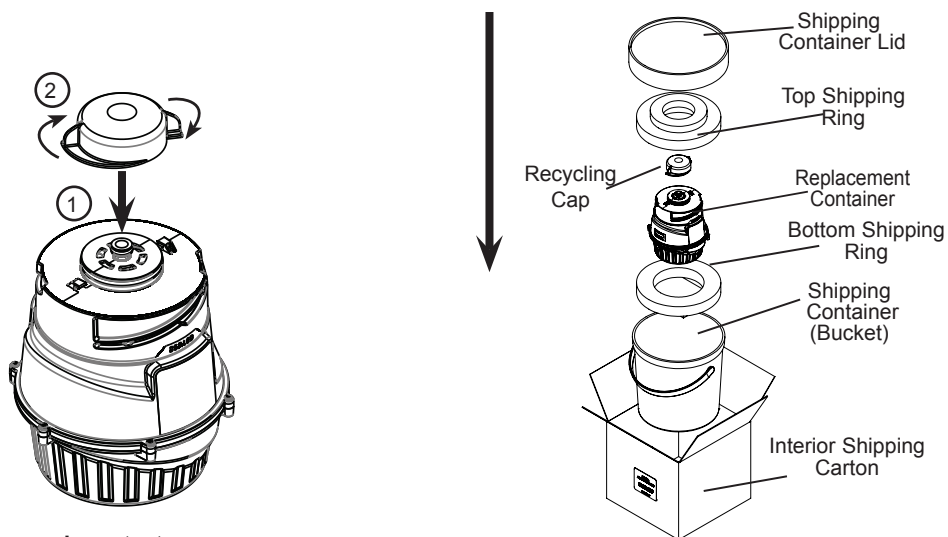

Important:
Make sure to install and secure Recycling Cap onto Collection Container.

Important:
Make sure to pack Container with supplied shipping rings.

Figure 4. Packing Container for Shipment to Recycling Vendor

For over 50 years, Air Techniques has been a leading innovator and manufacturer of dental products. Our priority is ensuring complete satisfaction by manufacturing reliable products and providing excellent customer and technical support. Whether the need is digital imaging, utility room equipment or merchandise, Air Techniques can provide the solution via our network of authorized professional dealers. Proudly designed, tested and manufactured in the U.S., our products are helping dental professionals take their practices to the next level.

Air Techniques' family of quality products for the dental professional include:

- Digital Imaging**
 - Digital Radiography
 - Intraoral Camera
 - Caries Detection Aid
 - Intraoral X-ray
 - Film Processors

- Utility Room**
 - Dry Vacuums
 - Wet Vacuums
 - Air Compressors
 - Amalgam Separator
 - Utility Accessories
 - Utility Packages

- Merchandise**
 - Evacuation System Cleaner
 - Imaging Accessories
 - Chemistry
 - Processor Accessories

Corporate Headquarters

1295 Walt Whitman Road | Melville, New York 11747- 3062 | Phone: 800-247-8324 | Fax: 888-247-8481

www.airtechniques.com



© 2017 Air Techniques, Inc. • PN A1647 Rev. A • March 2020