

Lead Free* Remote Water Control Valve Installation Instructions

* All applicable components that are used in this device are certified and/or compliant with NSF/ANSI/CAN 372, as required by the Safe Drinking Water Act, section 1417

General.

The Remote Control Valve assembly mounts in a horizontal run of water pipes readily accessible to the installer. Install the assembly in an area protected from freezing and direct sunlight.

Inlet and outlet connections are FNPT thread type unions. Two MNPT X sweat adapters are supplied. The installer must provide suitable reducer fittings when available inlet or outlet pipes are other than the purchased system's nominal pipe size

- All solder used must be lead free.
- Avoid excessive heat when soldering any fitting.
- Water pressure must not exceed 100 psi.
- Water temperature must not exceed 100°F.

Nominal Pipe Size (Inches)	Part Number				
	Item	Overall Length (Inches)		Overall Height (Inches)	
		¾	1	1¼	1½
With Filter (24V)	P/N	53020	53170	53525	53550
	L	23	27-1/2	28-1/2	31-1/8
	H	18	20	23-1/2	25-1/2
With Filter (120V)	P/N	53020-1	53171	53530	53555
	L	23	27-1/2	28-1/2	31-1/8
	H	18	20	23-1/2	25-1/2
Without Filter (24V)	P/N	53021	53173	53535	53560
	L	17-3/8	20	20-1/2	23-3/8
	H	8	9-1/2	13-1/8	14-5/8
Without Filter (120V)	P/N	53021-1	53174	53540	53565
	L	17-3/8	20	20-1/2	23-3/8
	H	8	9-1/2	13-1/8	14-5/8

Valve Position & Flow Direction

Inlet is on left and discharge is on right, which may be reversed as follows:

1. Disconnect the solenoid valve assembly (V) from the valves (S and T) at the two unions (U).
2. Rotate 180 degrees.
3. Retighten the two unions (U) to (V).
4. Be sure that water flow direction is into "IN" side of solenoid valve assembly (V).

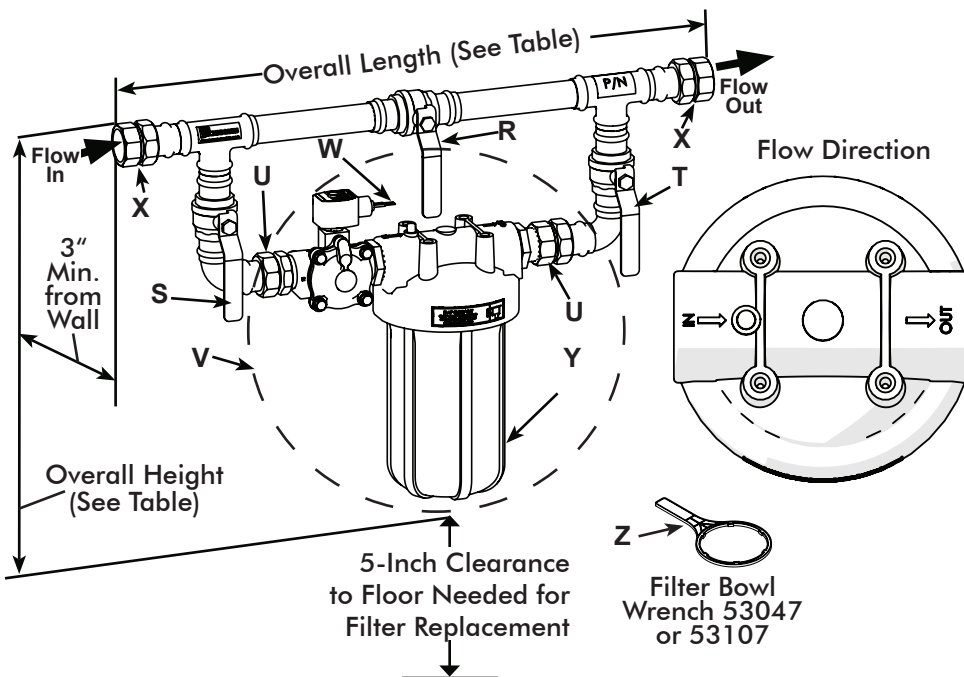

Remote Control Valve Key Components

Item	Description
R	Upper Control Valve
S	Inlet Control Valve
T	Outlet Control Valve
U	Solenoid and Filter Assembly Unions
V	Solenoid and Filter Assembly
W	18-3 AWG cable to Remote Panel or Switch
X	FNPT Thread Type Union
Y	Filter Bowl
Z	Filter Bowl Wrench

Electrical Connections

24-Volt System. All models ship from the factory operating from 24 volts via the water system transformer. Make appropriate electrical connections per the 24-Volt Electrical Transformer Connection Drawing shown to the right.

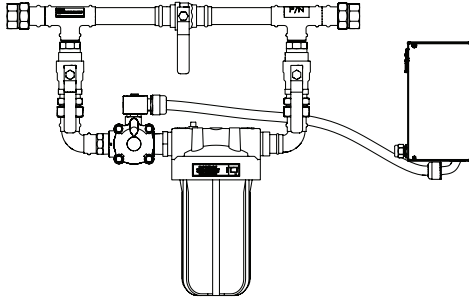

Water System with Transformer

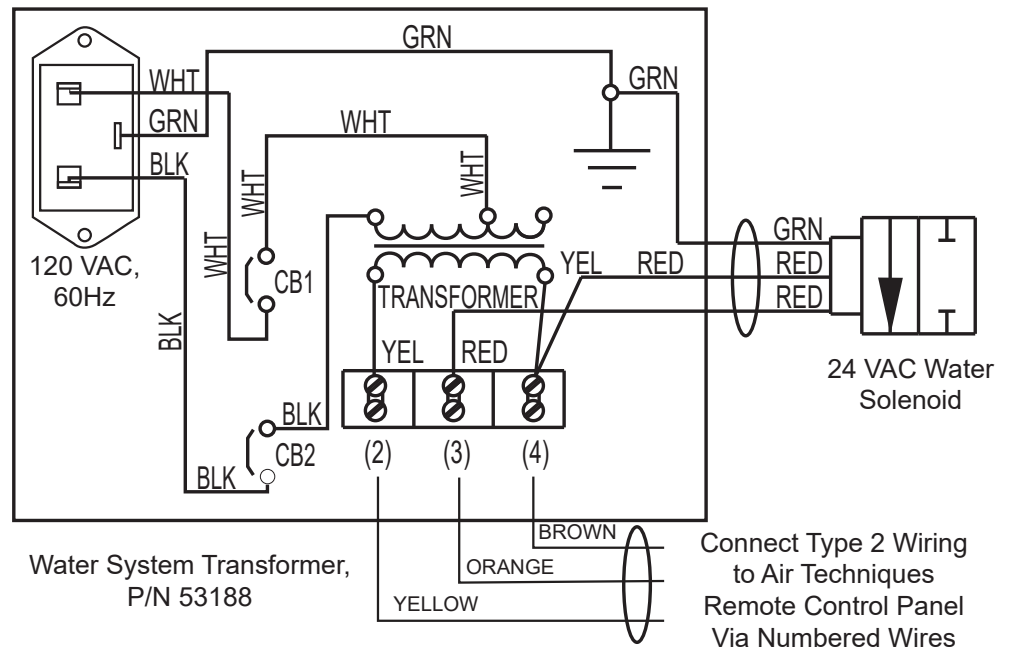

120-Volt System. To allow the system to operate via 120 volts, the 24 V water solenoid coil must be replaced with a supplied 120 V coil. Change the solenoid coil and then make connections as shown. Instructions to change the coil are provided below.

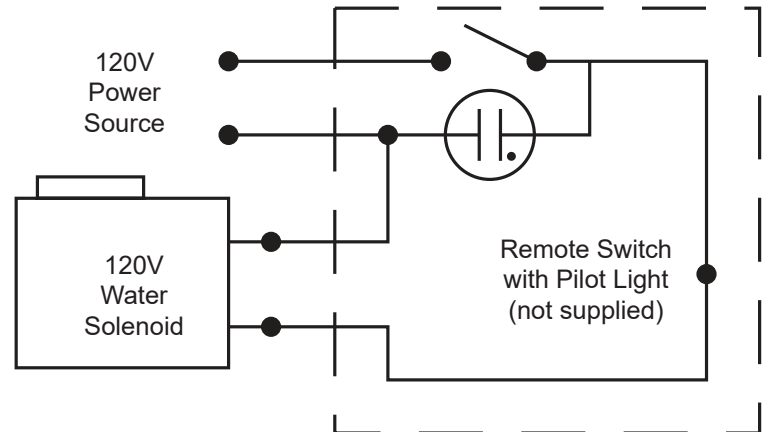

Solenoid Coil Replacement - Change from 24 V to 120 VAC

When operating the system from 120 VAC power, the 24 V water solenoid coil must be replaced with a 120-volt coil.

1. Disconnect conduit, coil leads, and grounding wire.

Note: Any optional parts attached to the old solenoid must be reinstalled on the new solenoid.

2. Snap off red cap from top of solenoid base sub-assembly.
3. Push down on solenoid. Then using a suitable screwdriver, insert blade between solenoid spacer and nameplate/retainer. Pry up slightly and push to remove.
4. Remove solenoid spacer and solenoid from solenoid base subassembly.
5. Install the 120 VAC coil. Reassemble in reverse order of disassembly.

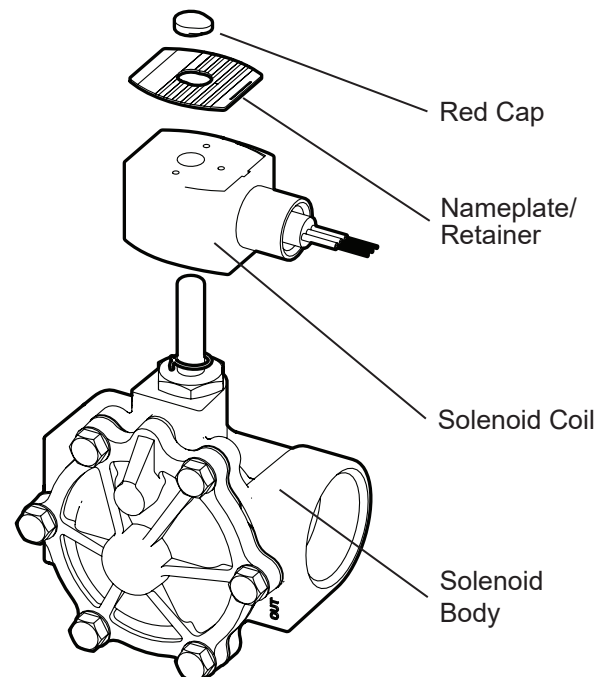

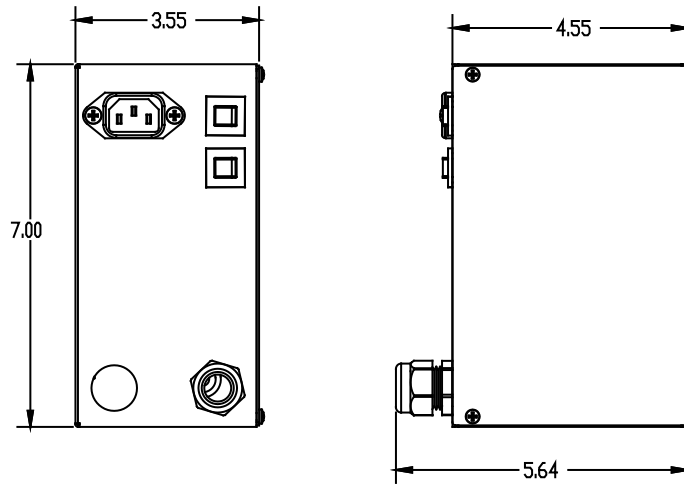

Water System Transformer, Part Number 53188, Dimensions

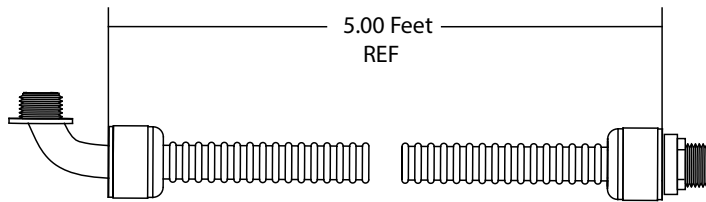

Water System Transformer Helix Tubing Dimensions

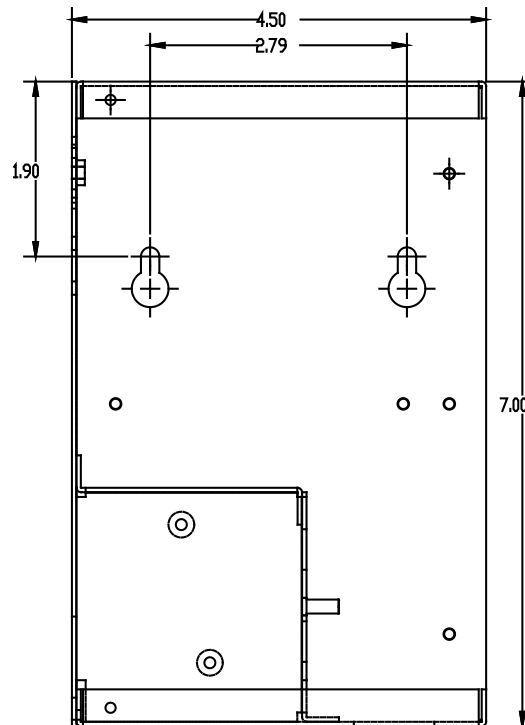

Water System Transformer,
Part Number 53188, Mounting Orientation

Note:
All dimensions are in inches unless otherwise specified.

Filter Element Replacement (Only for models with a filter)

When the water flow at the tap is noticeably reduced, it is time to change the cartridge. Excessively hard water will decrease the service life of each filter element.

WARNING: The filter must be protected against freezing. Failure to do so may result in cracking of the filter and water leakage.

1. Filter Bowl Removal

Perform the following procedure to remove the Filter Bowl.

- Place the Upper Control Valve (**R**) in the open position.
- Turn off both the Inlet and Outlet Control Valves (**S and T**).
- Release housing pressure by depressing the red pressure release button. Make sure all air escapes.
- Using the Filter Bowl Wrench, unscrew and remove the Filter Bowl from the cap.
- Discard used filter element and replace with new filter element.

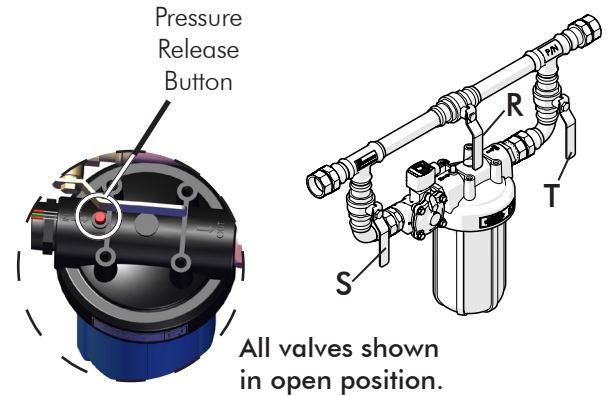

IMPORTANT: When opening the Filter Bowl to install or change the filter element it is common for the O-ring seal to lift out of the groove and at times, it may even stick to the cap. Make sure that the O-ring is properly seated each time the unit is reassembled or a water leak could occur.

2. O-ring Seal Re-seating

The rubber (Buna-N) O-ring is pressed into the groove at bottom of threads. It fits into the groove in the sump (lower housing) providing a water-tight seal between the cap and the sump. Re-seat the O-ring by performing the following procedure.

- Wipe the O-ring clean with a clean rag.
- Lubricate the O-ring with a very light coating of white petroleum jelly (Vaseline, for example).

IMPORTANT: Do not wipe the O-ring clean of lubricant after it has been properly seated in the groove. The lubricant prevents “crawling” of the O-ring when tightening the cap. A not properly lubricated O-ring could cause a leakage condition.

- Place in the groove of the Filter Bowl and with two fingers wipe the O-ring down into the groove. The O-ring is a full fit type and the wiping down operation assures it is properly seated.

3. Filter Bowl Installation

Perform the following procedure to install the Filter Bowl with new filter element.

- Insert new filter element into housing making sure that the cartridge is properly seated.
- Screw the Filter Bowl onto the cap and hand tighten.
- Open the Inlet and Outlet Control Valves (**S and T**) one-quarter turn and depress the red pressure release button.
- When all air has escaped from the system, fully open both the Inlet and Outlet Control Valves (**S and T**).
- Place the Upper Control Valve (**R**) in the closed position.

Warranty

The Remote Control Valve assembly is warranted to be free from defects in material and workmanship from the date of installation for a period of 2 years (24 months). Each is designed solely for use in a dental office environment and this warranty is not applicable to other applications.

www.airtechniques.com



Air Techniques, Inc.
1295 Walt Whitman Road
Melville, New York, USA 11747-3062

